

# Audio Note Kits

## Instruction Manual

### DAC Kit 3.1/4.1

Manual Version 2.2 – March 2011



Build instructions for DAC3.1, DAC3.1 Signature, DAC4.1 Limited Edition

# Table of Contents

Section 1: Introduction .....	4
Overview .....	5
Component Placement Breakdown .....	6
Electrical Safety Warning .....	8
Section 2: Mechanical Assembly .....	9
Installing the feet .....	9
Mains Transformer, Choke, and Mains Installation .....	9
Configuring the Primary Winding for your World Region .....	11
Installing the IEC Socket (AC Socket) and Rocker Switch .....	14
Installing the Choke .....	15
Installing the Mains Transformer .....	15
Wiring up the Mains .....	16
Shield Positioning .....	17
Section 3: M2 Power Supply .....	19
M2 Power Supply Board Parts List .....	20
M2 Power Supply Board Construction Steps .....	21
Installing the Valve Bases .....	21
Installing the Resistors .....	23
Installing resistors in the HT ADJUST position .....	25
Zener Diode Installation .....	26
Electrolytic Capacitor Installation .....	27
Installing the Bridge Rectifier .....	29
Installing the Non-Polarized Capacitors .....	29
Wiring the M2 Power Supply Board .....	30
Filament Component Section of the M2 Power Supply Board .....	33
Regulator Installation .....	34
Installing the LED Harness .....	35
Remaining Wire Connections .....	35
Installing the Heatsink .....	36
Installing the Choke Wire .....	37
Inter-wiring to the Mains Transformer .....	38
Securing the Regulators to the Heatsink .....	41
Section 4: M2 Power Supply Testing .....	43
Preparations .....	43
Fitting the Mains Fuse .....	43
Installing the LED Indicator .....	44
Installing the tubes .....	44
Tidying Up .....	44
Ohm Check .....	45
Electrical Testing .....	45
Voltage Check Summary .....	47
DC Voltage Checks .....	47
AC Voltage Checks .....	47
Section 5: Digital Power Supply PCB .....	48
Parts List .....	48
Construction .....	48
Installing the LED's .....	49
Installing the Capacitors .....	49
Installing the Diodes .....	50
Installing the Resistors .....	51
Board Installation and Wiring .....	52
Section 6: Install the Screen .....	54
Section 7: Installing the Digital PCB .....	55
Digital Board Overview .....	55

Digital Board Installation .....	56
Section 8: Digital Board Power Supply Connections .....	57
Section 9: Line Board Construction .....	58
Installing the Valve Bases .....	58
Parts List .....	58
Installing the Resistors .....	59
Installing the Electrolytic Capacitors.....	61
Installing the Film (non-polarized) Capacitors .....	61
Board Orientation .....	62
5687 Filament Wiring .....	62
Section 10: Installing I/V transformers .....	63
Wiring the I/V Transformers .....	64
Section 11: Connecting the 5687 Output .....	65
Connecting the 5687 HT to the power supply .....	65
Connecting the Output Transformers .....	65
Output Transformer Type 1 (Single-ended Only) .....	66
Output Transformer Type 2 (Single-ended or Balanced).....	67
Section 12: Source Selection and Switching .....	68
Installing the Input Selector Switch .....	68
Input Connections .....	69
Connecting the RCA Input .....	70
Connecting the USB Input .....	72
Connecting the XLR Input .....	73
Section 13: Turn-on Procedure.....	74
Final Thoughts .....	75
Appendix.....	76
Resistor Color Code Reference .....	77
Analog Board Schematic.....	78
M2 Power Supply Board Schematic.....	79

# Section1: Introduction

**NOTE:** This manual is for the DAC3.1, DAC3.1 Signature, and DAC4.1 kits - The kits are all the same except that the component level is increased with each kit the - The DAC3.1 can come as RCA or RCA/Balanced while the DAC4.1 using the C-core output transformers comes in RCA/Balanced.

Thanks for purchasing the AudioNote DAC Kit 3.1 or 4.1. Our goal is to provide you with the highest quality Kit that you will build from scratch with these instructions. If you have any questions or comments during the build feel free to contact us and we would be happy to help out.

You will need a soldering iron or soldering station with a sponge along with wire strippers and a Phillips screwdriver. A nut driver or a pair of pliers would be useful as well. We have divided the manual up into a series of step-by-step instructions for the successful build and debug of the kit. There are several places during the build that you will perform tests and/or checks to make sure that you are on track. This way when you complete the kit you will know that all the major sections are working.

You will find a number of component bags supplied with your kit. These bags will be referred to throughout this manual.

Here are some tips from working with many kit builders over the last few years:

- Perform your work in small manageable chunks. Do not be in a hurry to listen to your finished kit.
- Savor the build experience. Here's a chance to really get to know your audio kit that will give you many hours of enjoyment.
- Better to work on a section and then spend the time to check over the section rather than just carrying on.
- The kit building experience should be a pleasant one so find a place that you can build the kit with relative peace so you can concentrate on the instructions.
- If you plan for a long build stretch on a Saturday afternoon for example then take plenty of breaks with constant re-checks of your work.

Whilst working through this manual, please feel free to give us your feedback and any other information that may allow us to improve the build experience.

## Overview

Here is a rough guide to the steps you will be following. You may want to use this page as a general checklist, crossing out each item as it is done.

1. Install Feet on Chassis
2. Install M2 Mains Transformer and Choke into chassis
3. Connect up IEC section (IEC/rocker, Mains transformer)
4. Build M2 Power Supply Board
5. Wire up Mains transformer to M2 power supply
6. Build DAC PS PCB
7. Wire up Mains transformer to DAC PS board
8. Build 5687 analog Board
9. Wire up Filaments and HT from M2 Power supply Board
10. Install Digital Board in chassis
11. Connect Digital Power Supply leads to Digital Board
12. Connect Digital Board to 5687 Board (via IV transformers)
13. Connect 5687 analog board to output transformers
14. Connect output transformers to audio outputs

# Component Placement Breakdown

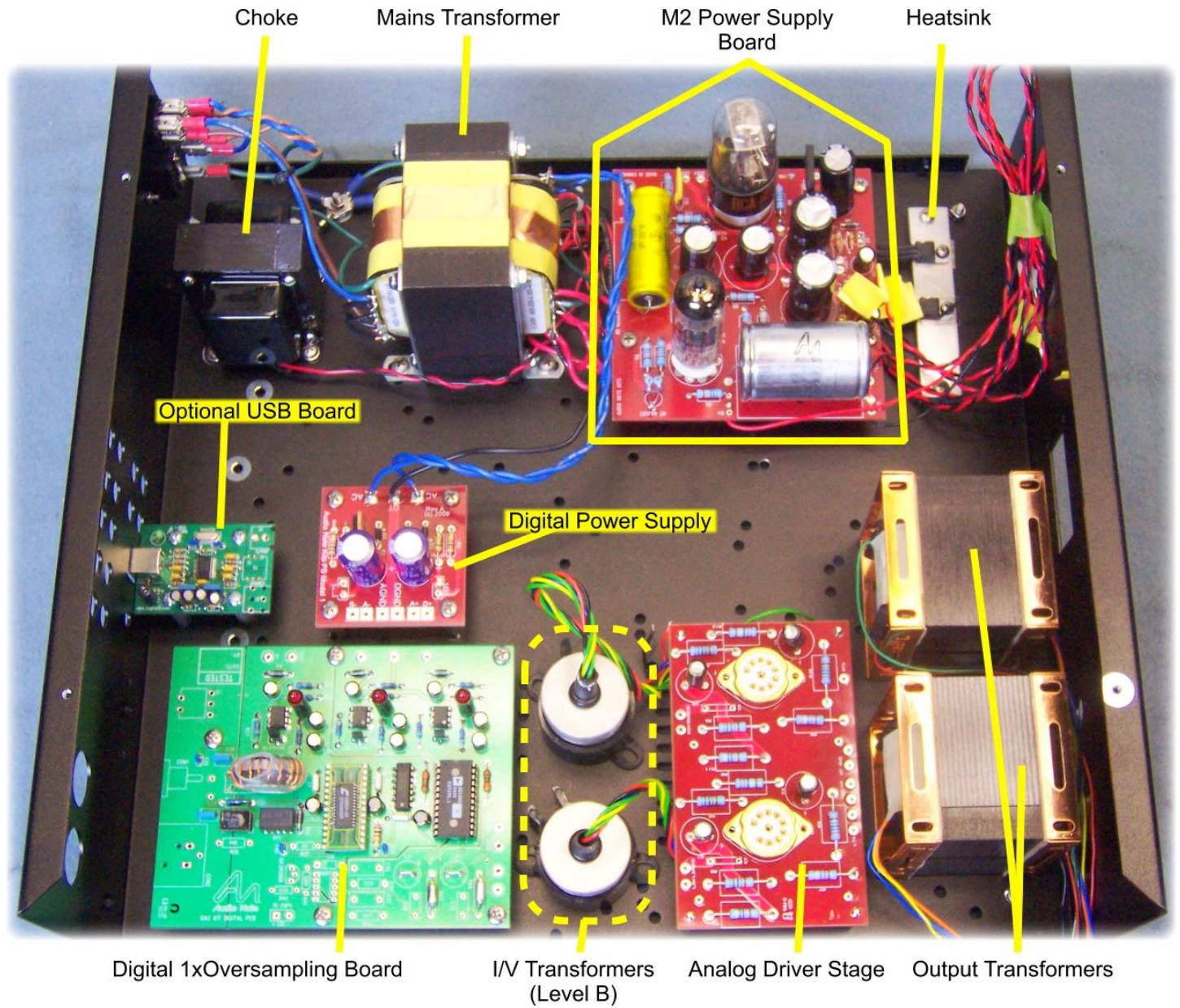

The graphic below shows the block diagram overview of how the DAC works:

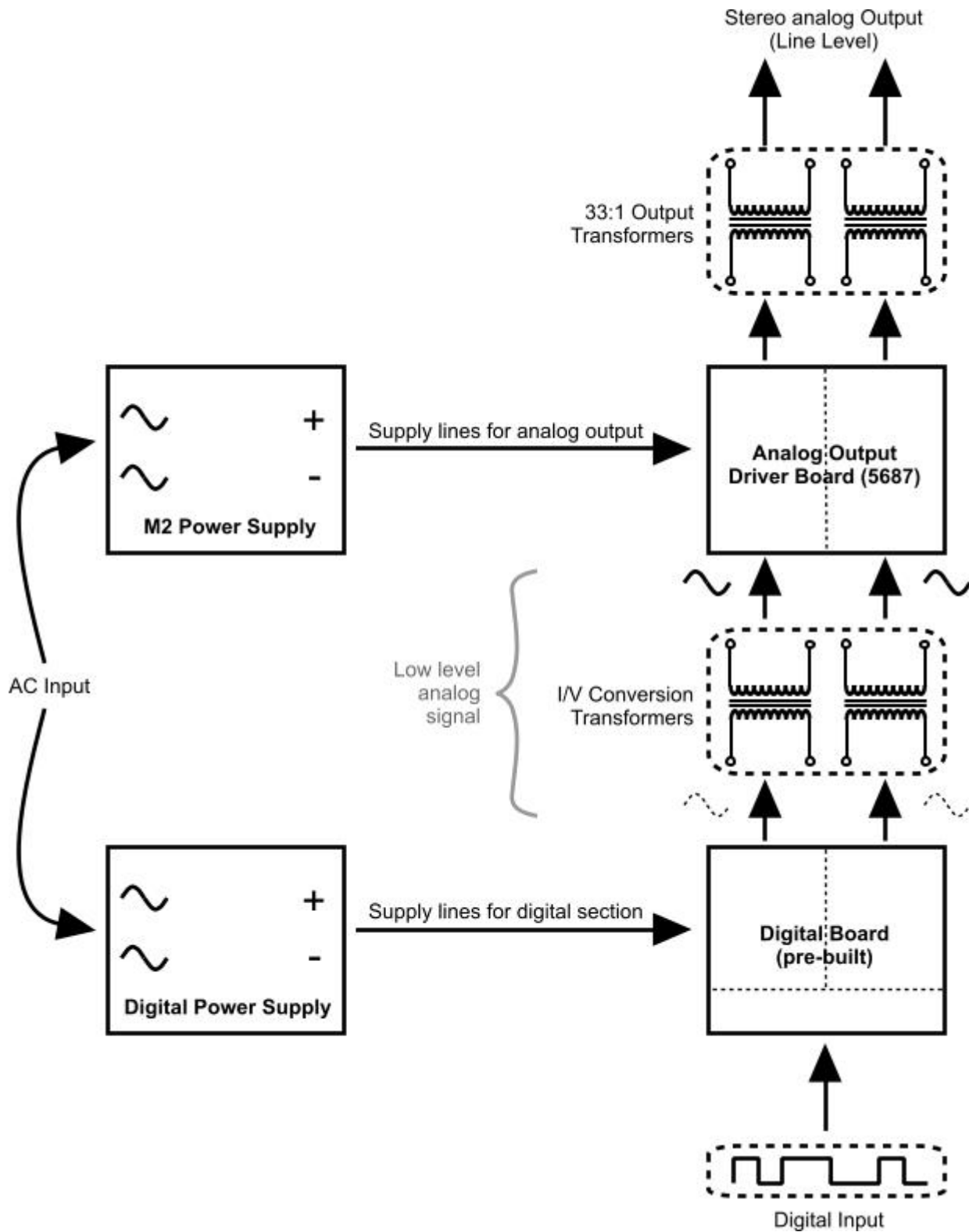

## ***Electrical Safety Warning***



There are sufficient voltages in this kit to give you a very nasty and harmful shock so be careful when powering on, debugging, and probing around.

Please be aware of proper electrical safety.

Please contact AudioNote kits via phone or email to discuss any precautions necessary when building the kit if you feel unsure about what you are doing at any stage of the build.

## Section 2: Mechanical Assembly

In this beginning section we will start by installing the 4 feet from the Fittings Bag then we will install the Mains transformer and Choke as shown in the pictures below.

### *Installing the feet*



Insert 4 feet in the bottom of the chassis.

Fix them each in place using an M4 nut and washer.

### *Mains Transformer, Choke, and Mains Installation*

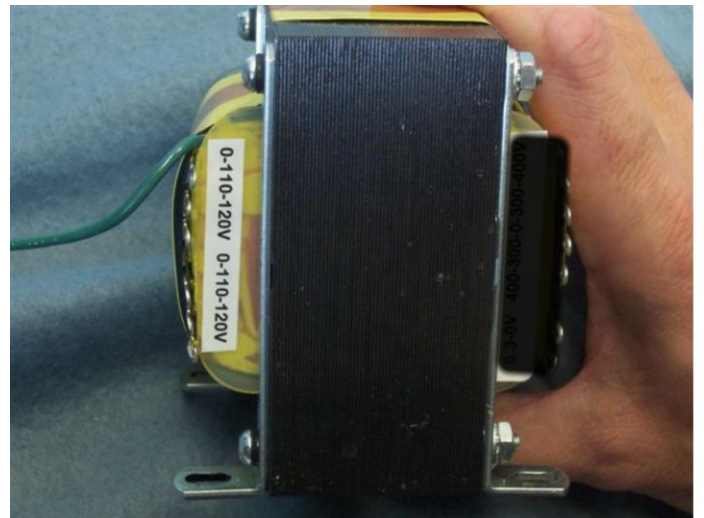
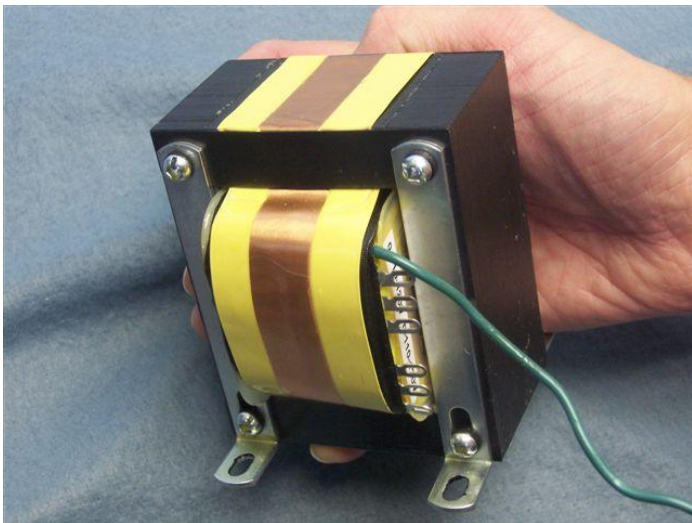

Above you can see the Mains transformer that is used with the M2 Power Supply. The first step is to take the supplied M4 GND lug from the Hardware Bag and solder it to the end of the green wire.

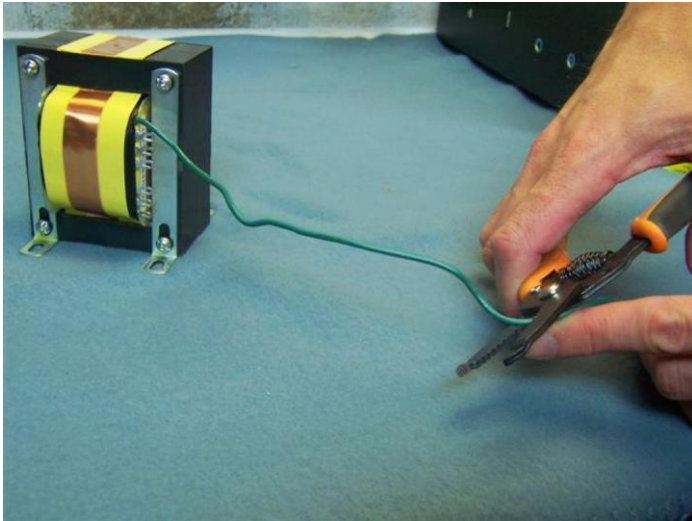

Trim the wire to about \_\_\_ inches.

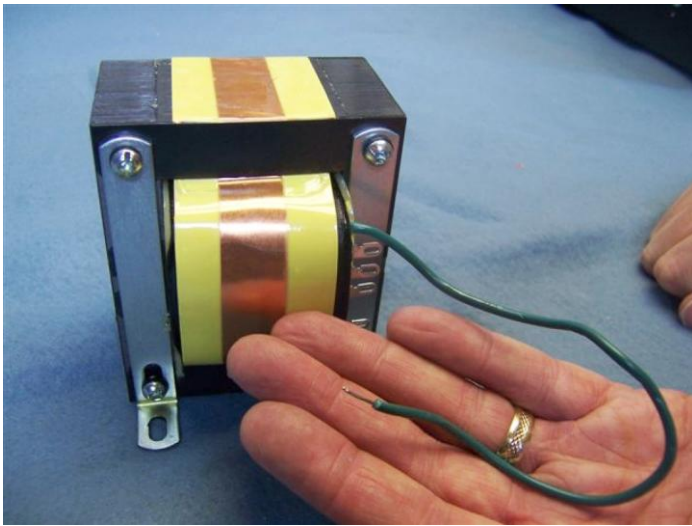

Strip about 1/4" of insulation off the end of the green wire.

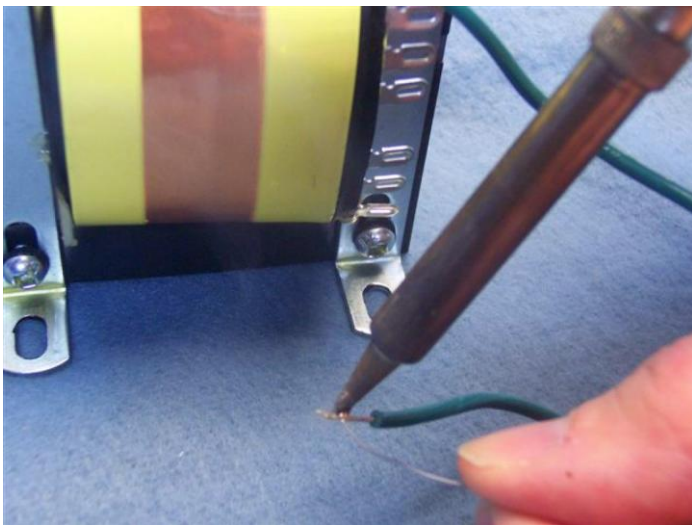

Tin the bare wire by adding solder to the end.

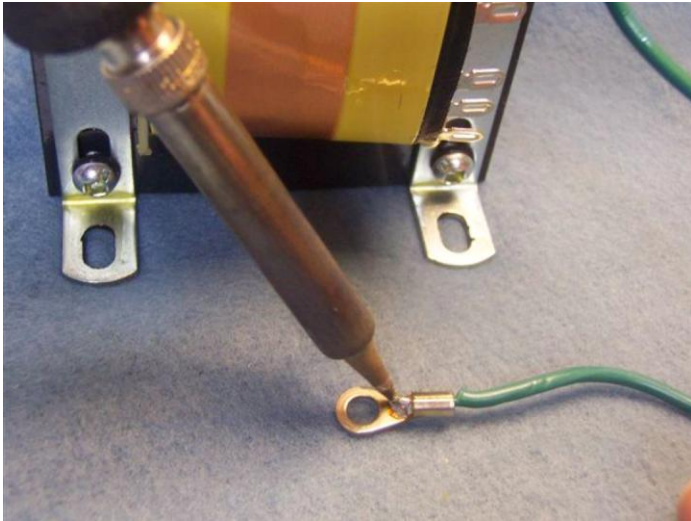

Add solder to secure the GND Lug to the end of the wire.

### Configuring the Primary Winding for your World Region

Next step is to decide what world voltage you require – for example we have some of the most popular regions listed below:

United States	120v
Canada	120v
UK	230v or 240v
Europe	230v / 240v
Hong Kong	220v

In order to wire up the for 120V operation we will need to connect the primaries as shown below:

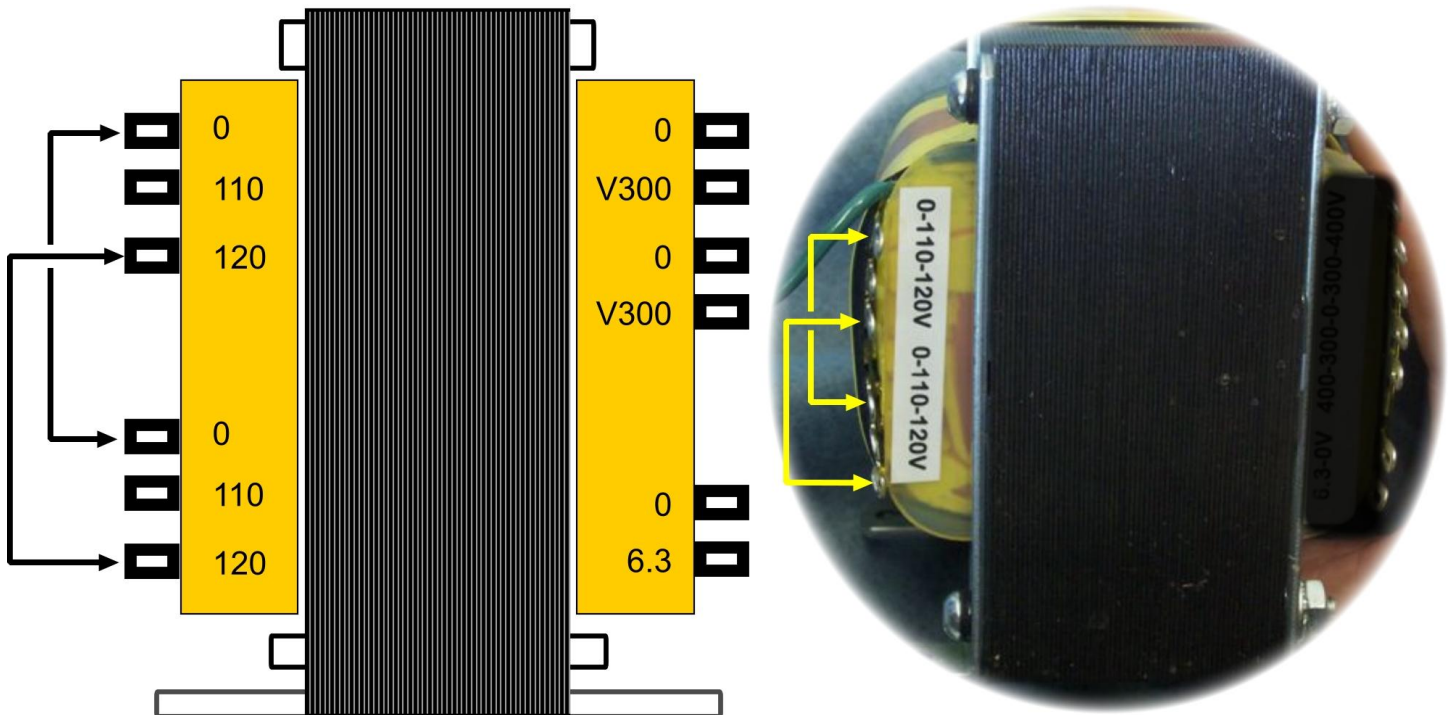

The graphic shows above the correct wiring for of the Primaries for 120V operation where the 0 of one winding connects to the 0 of the second winding & the 120 of one winding connects to the 120 of the second primary winding. Check the chart on the next page for the correct PRIMARY winding for the world Voltage you live in.

## Regional Mains Variations - Primary Wiring

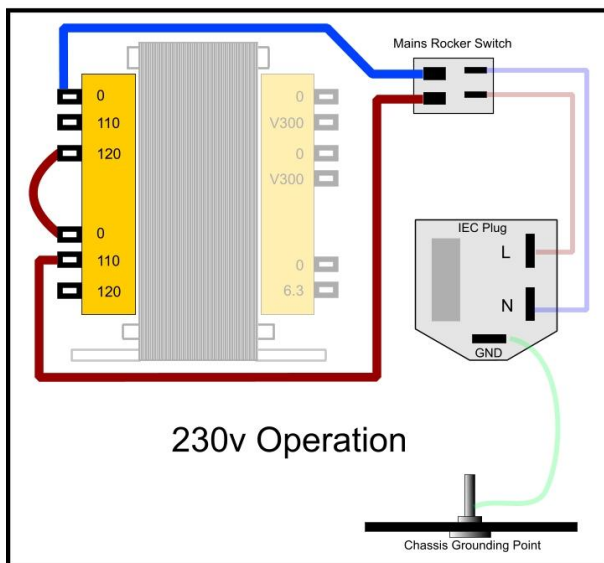
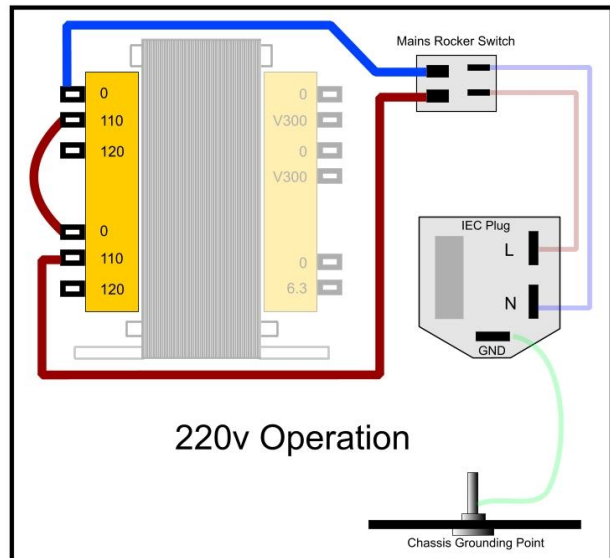
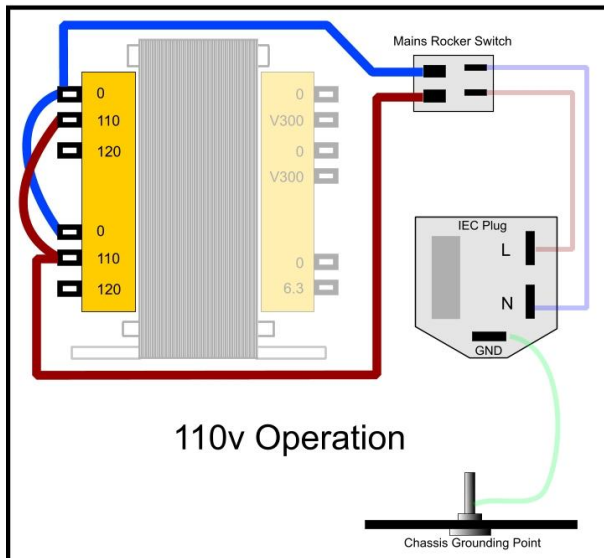
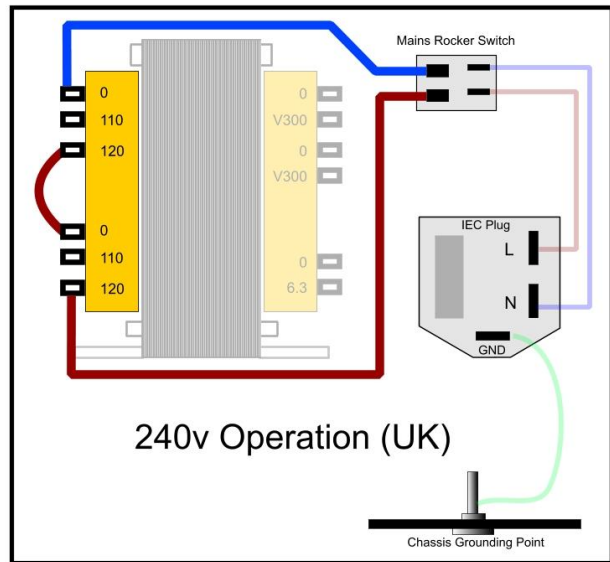
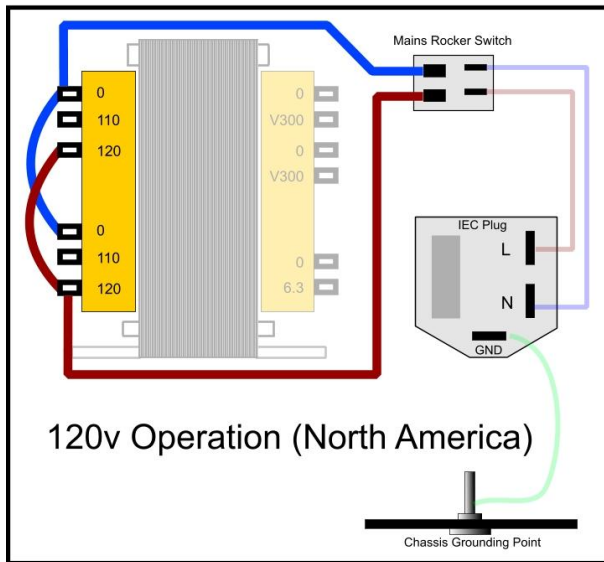

Now we must configure our Mains transformer for the World Voltage that we reside in. **For this example we will show 120V Operation.**



Start by cutting two short pieces of wire approx 2" in length each, stripping the insulation off the ends and tinning the wire.



Then we will inter-wire the Mains transformer primaries.

*Remember, we are wiring here for 120v - if your region is different then you will need to consult the wiring chart on the previous page to determine how you inter-wire for your region.*

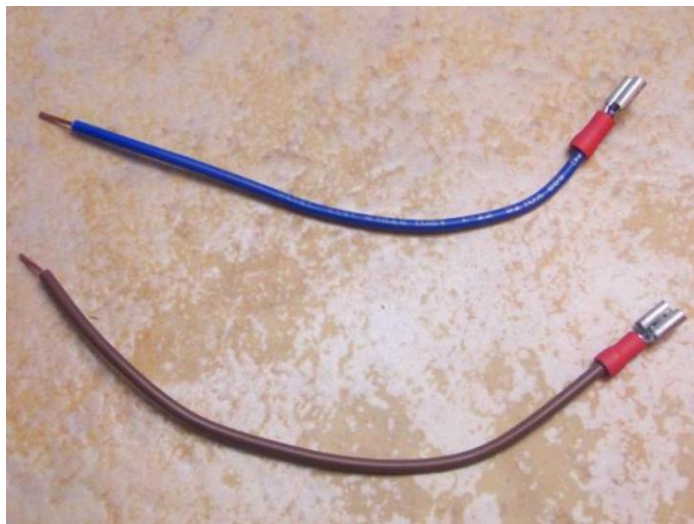

From the IEC bag we want to take the brown and blue wires with the crimps on one end.

Trim the wires to about \_\_\_\_\_ inches in length and then solder on to the correct Mains transformer primary tags for your region.

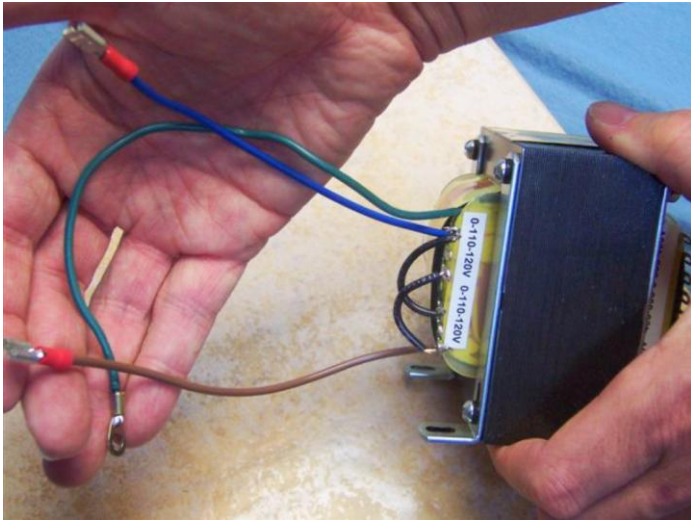

Here, the wires are soldered onto the top-most 0v and the bottom-most 120v for North American/Canadian 120v.

*Remember, we are wiring here for 120v - if your region is different then you will need to consult the regional wiring chart to determine how you inter-wire for your region.*

## Installing the IEC Socket (AC Socket) and Rocker Switch



The rocker switch simply snaps into place in the chassis slot.

Use the CSK M3 10mm screw and M3 nut to secure the IEC socket into position.

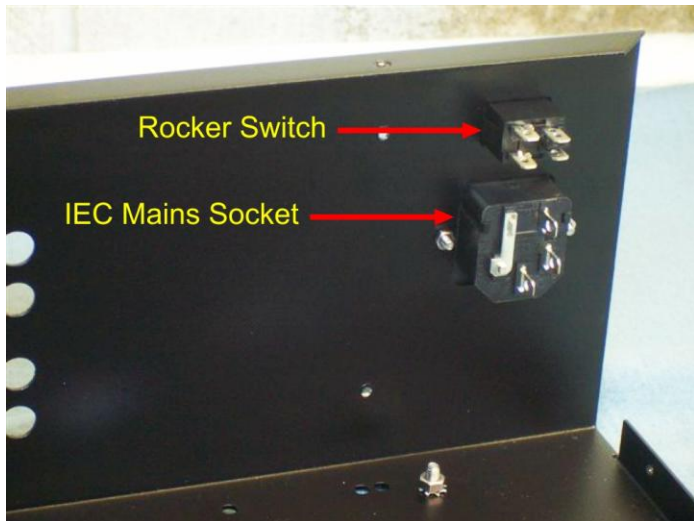

Here you can see the correct installation of the IEC socket and rocker switch from inside the chassis.

## Installing the Choke

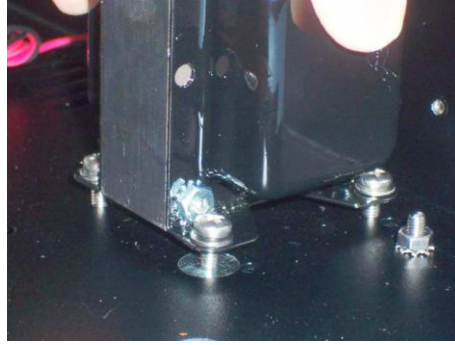
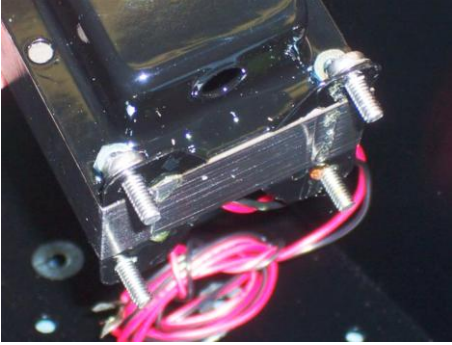

Since the Choke fits into a tight location we suggest you put the screws and washers into position through the holes in the choke covers – then lower the choke into position making sure that you align with the non painted hole - see opposite.

Note the wires at the back of the choke.

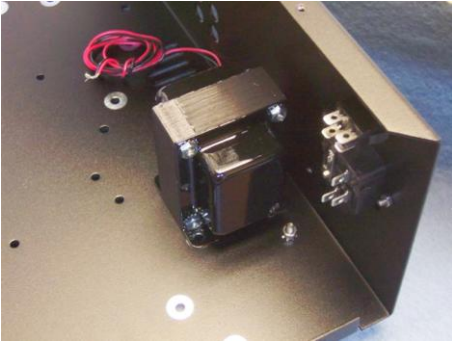

The left-most picture shows the final position of the choke from inside the chassis.

The central picture shows its position under the chassis where you will now secure the 4 holes of the choke with serrated M4 washers and M4 nuts.

## Installing the Mains Transformer

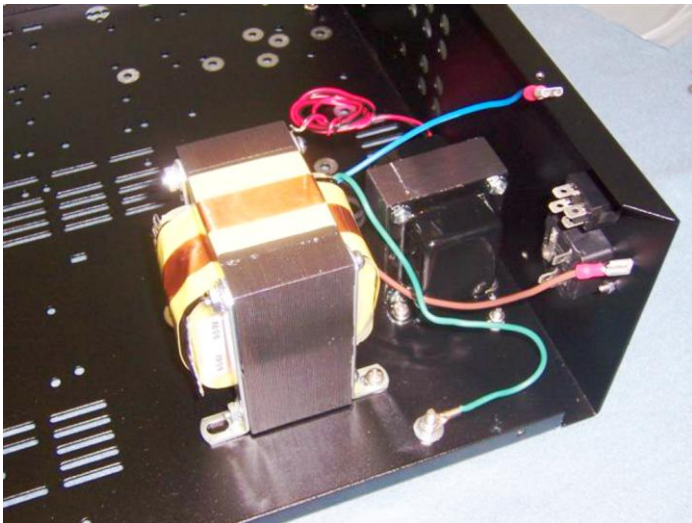

The picture opposite shows the correct orientation for the Mains Transformer.

The following instructions will show how this is achieved.

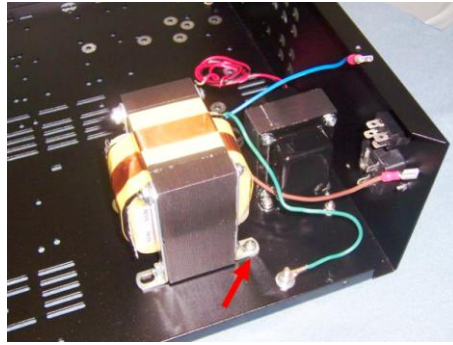
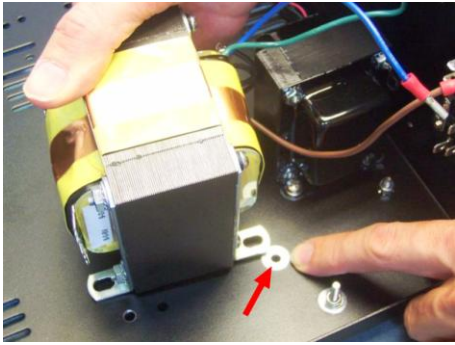

When installing the Mains transformer be sure to line it up with the unpainted hole in order to ensure a ground connection.

Secure the transformer at all four corners.

## Wiring up the Mains

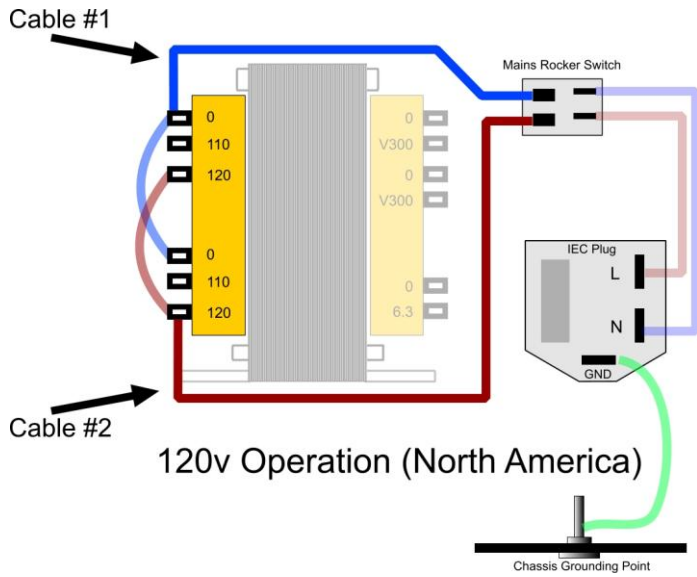

Once the transformer is installed you can connect up the Blue and Brown Crimped wires from the Mains transformer directly to the Rocker Switch.

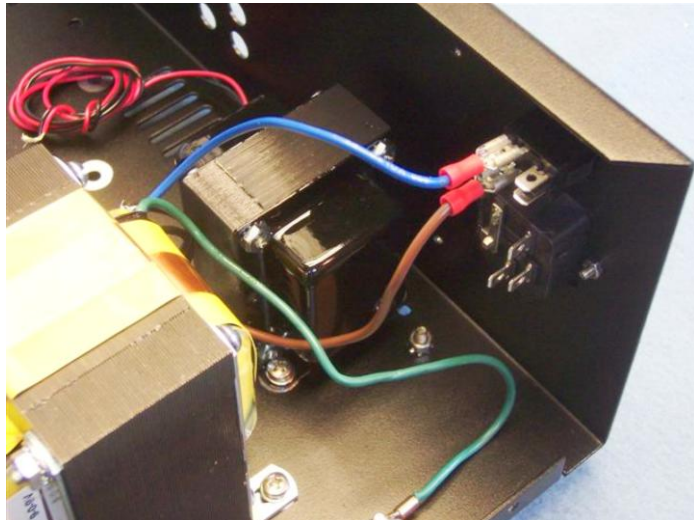

Also connect the green earth wire from the mains transformer to the GND lug as shown opposite.

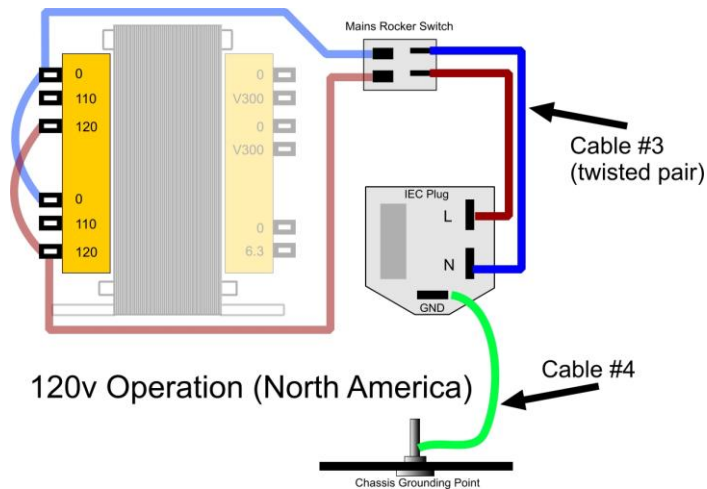

Add the twisted wire (Cable #3) and the ground wire (Cable #4) as shown in the graphic opposite.

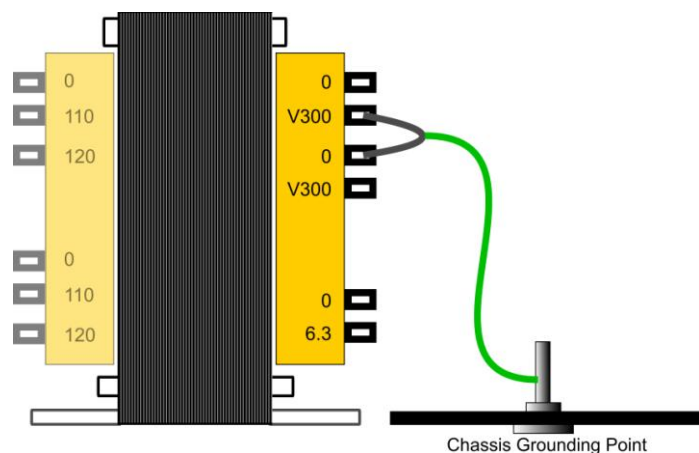

Let's add one final GROUND wire connection from the M4 screw in the chassis.

Take a piece of bare wire and solder it between the V300 and 0 terminals as shown opposite. Next, take a terminated ground wire and strip the un-terminated end and solder it to the short that you have just made. The other, terminated, end connects to the chassis ground post.

## Shield Positioning

I would like to explain where the shield fits at this stage – **you won't actually be installing this until the end of the build** but by then there will be a number of things inside the chassis.

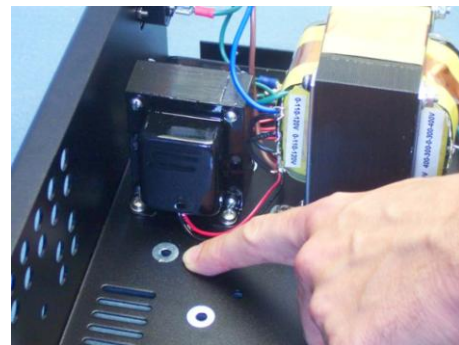
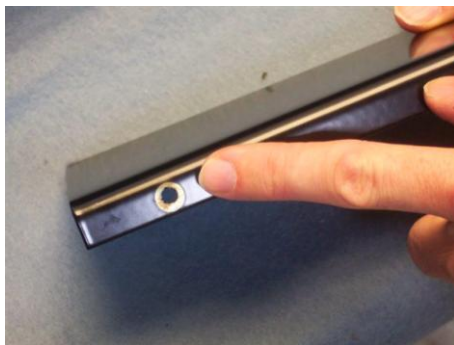

Take a look at the shield provided and locate the hole underneath that has no paint on it – this will match up with a hole on the chassis that is also unpainted in order to ensure a good grounding of the SHIELD when in stalled in the chassis.

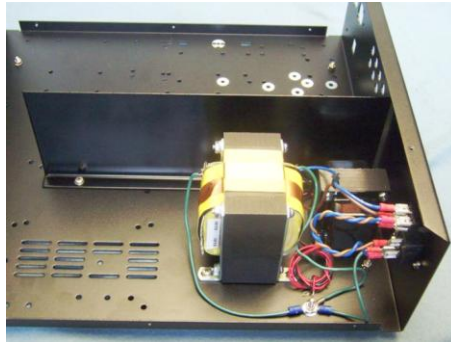
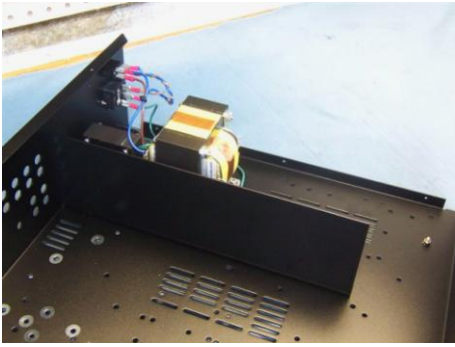

Here you can see the correct installation of the shield – You will need to remove it later on when we wire up to the Mains transformer but for now you can leave it in and show off your wonderful work to your wife!

This concludes the IEC Wiring section for the Mains Transformer.

You may want to double-check your work at this point. Also, make sure that the crimped end on the Rocker switch are not coming into contact with each other - make sure there is plenty of clearance. If you want to add some solder to hold them into place that is fine but I would wait a little bit. Also remember that you can use the rubber hoods that are supplied to cover up the rocker and IEC plug and it is a matter of threading the crimped end through the rubber hood.

With this section completed we are going to move onto the building of the M2 Power Supply Board.

## Section 3: M2 Power Supply

In this section we will be assembling the M2 Power Supply Board PCB.

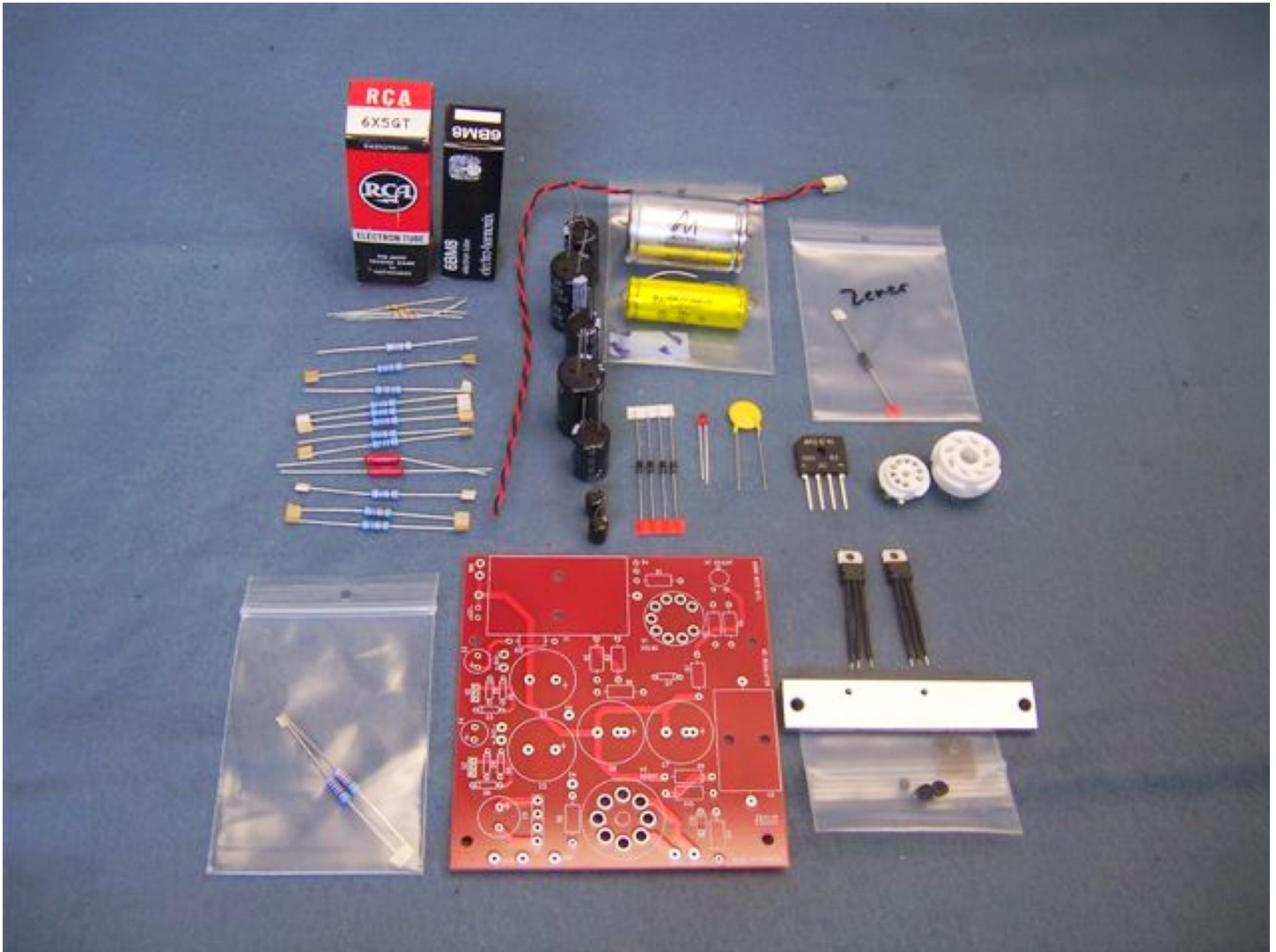

Here is a view of the parts that you will find in the M2 Power Supply Kit Bag

Most of the parts for this section can be found in the M2 Power Supply bag (although the filament wires may be located elsewhere).

For an experienced builder you can look at the parts list on the next page and get started but I would read through the step by step instructions as we feel that this is the best and most efficient error free method of building the board.

## M2 Power Supply Board Parts List

The Complete Parts list for the M2 board is shown below.

For resistor color code chart refer to the APPENDIX. You can also find an 'Interactive Resistor Color Code Calculator' on our website (available from the Links page).

Category	Quantity	Part	Designator
Capacitors (Electrolytic)	2	470uf 16V	C2, C4
	1	2200uF 35V	C9
	2	22uF 450V	C6 ,C7
	2	68uF 450V	C3, C5
Capacitors (Non-polarized)	1	Disc 4700uF 1000v	C10
	1	.22uf 600V	C8
	1	.47uF 600V	C1
Resistors	1	100R	R8
	2	1K0	R5, R6
	1	2K7	R12
	1	15K	R11
	1	33K	R2
	1	68K	R3
	2	100K	R1, R10
	1	150K	R7
	1	220K	R9
	1	470K	R4
Semiconductor Devices	1	KBU6J6A	U1
	1	3.5W 150V Zener	D7
	4	Zero Ohm Resistors	D1, D2, D4, D5
	2	1N4007	D3, D6
	2	78S12	U2, U3
Variable Resistor	1	50K 500mW	VR1
<b>NOTE:</b> This may be replaced with 2x 22K resistors			
Valve Bases	1	8 pin valve base	
	1	9 pin valve base	
Tubes	1	6X5 Tube	
	1	ECL82 / 6BM8 tube	

## M2 Power Supply Board Construction Steps

### Installing the Valve Bases

Lets start by installing the 8-pin valve base with correct orientation.

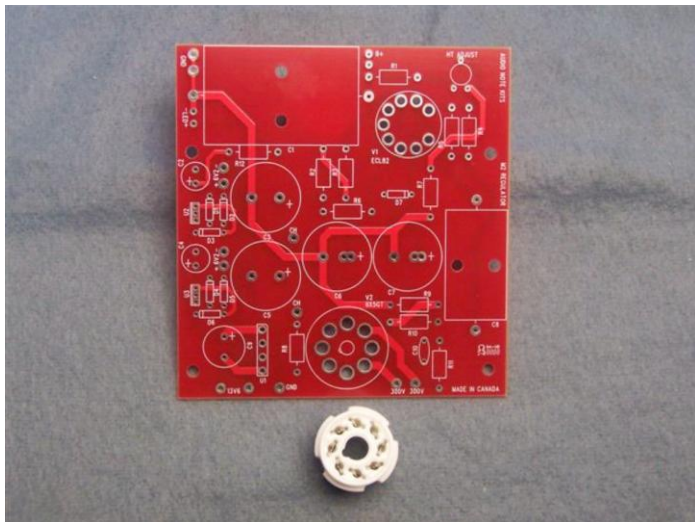

The 8-pin (octal) valve base is shown opposite.

It's a fairly tight fit into the board so take your time and make sure all the legs are individually positioned over the holes in the board.

Now, let's make sure we have the correct orientation - note the Notch on the valve base along with the Notch on the PCB. These need to line up - see next image.

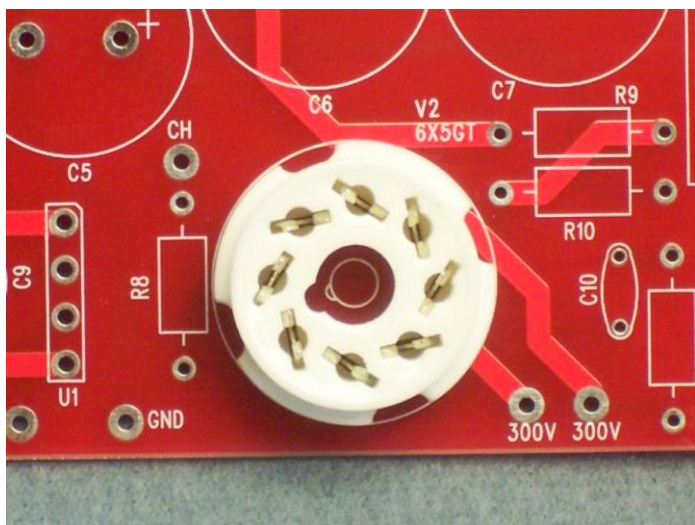

Here you can clearly see the notches lined up – this is a correct orientation of the 8-pin valve base.

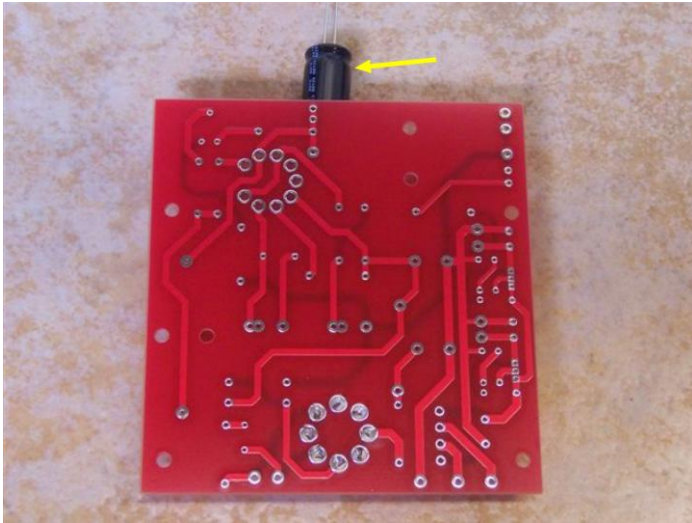

The next job is to solder the valve base into position – Once you have fitted the octal into position I suggest you use a cap or something to support the board so that it is nice and horizontal.

The reason for this is so that the valve base will be soldered into the board nice and level – you may want to solder a pin on one side and then the opposite and then double check that the valve base is nice and level see the following images.

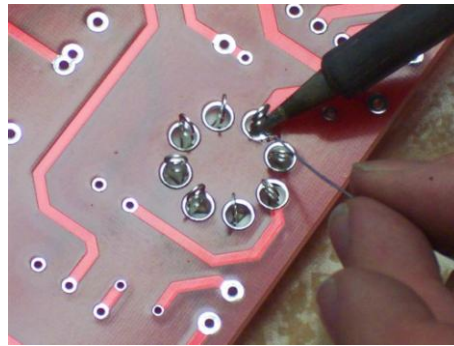
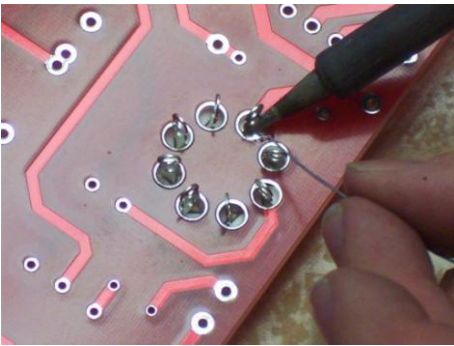

It is only necessary to solder half the valve base whole – feel free to put solder on the entire hole if you feel like you need to do so – I usually pick one side and solder the lead to the board – you may want to pull on the lead to make sure that it is all the way out – sometimes a valve base lead can stick in position.

Next step is to solder in the 9-pin valve base – this one only goes in one way so you can't really make a mistake. I would suggest using some tape though to make sure that the valve base is level to the board – then solder a pin on one side and then the other to make sure the valve base is level and that you are on track. See pictures below:

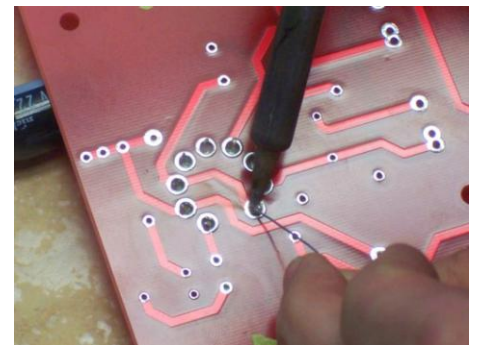
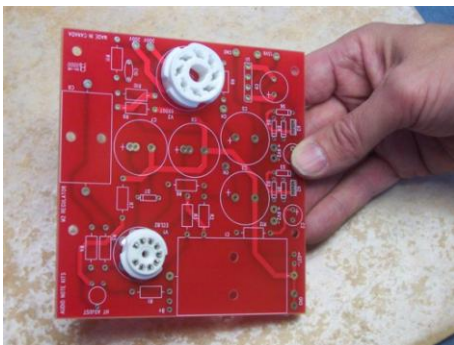

## Installing the Resistors

Resistors	Color Code	Quantity	Value	Designator
	Black, Black, Black, Black, Brown	1	100R	R8
	Brown, Black, Black, Black, Brown	2	1K0	R5, R6
	Red, Black, Black, Black, Brown	1	2K7	R12
	Brown, Green, Black, Black, Brown	1	15K	R11
	Brown, Orange, Black, Black, Brown	1	33K	R2
	Blue, Grey, Black, Black, Brown	1	68K	R3
	Brown, Black, Black, Orange, Brown	2	100K	R1, R10
	Brown, Green, Black, Orange, Brown	1	150K	R7
	Red, Red, Black, Orange, Brown	1	220K	R9
	Yellow, Purple, Black, Orange, Brown	1	470K	R4

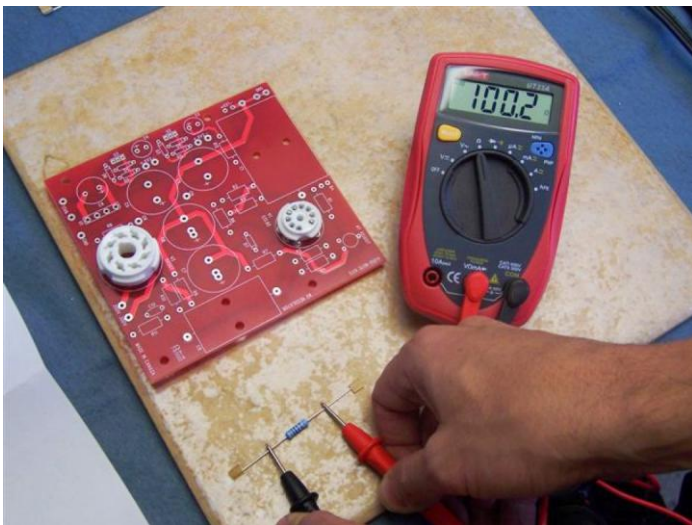

If you have a voltmeter you can check the value of each resistor prior to soldering in OR you can refer to the color code chart in the above parts list.

Identify the correct resistor and then install in the specified designator (R1 for example).

Resistors have no polarity so it does not matter the orientation but I find that if I stick to one direction from left to right it makes it a lot easier to read the resistors on the board.

**RESISTOR NAMING LESSON:** When a resistor has a value of lets say 10 ohms we will refer to this as 10R. If the resistor has a value of 10.5 ohms we would say 10R5. When a resistor value is 250 ohms we would say 250R – When it becomes 1000 ohms we say 1K or 1K0 or 1 Kilo ohm.

Its common to see 1K5 which would be like 1.5 K ohm or 1500 ohms – Just like when we get to 1 Mega Ohms we would say 1M or 1M0. For 1.2M we would use 1M2 – so this is the standard way of naming resistors – The first resistor we are going to install is the 100R or 100 ohm resistor!

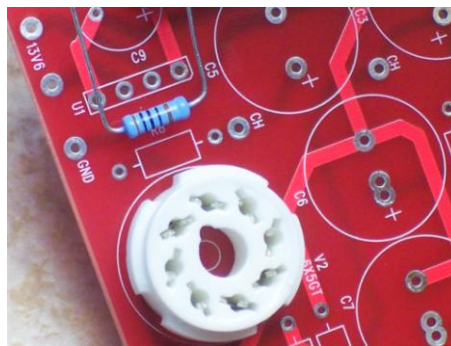
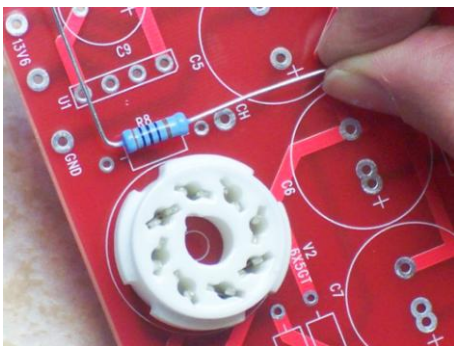

Here we are installing the 100R resistor.

You should locate the reference designator on the board (in this case it is R8) and then do an approx bend on the correct length as we have done opposite.

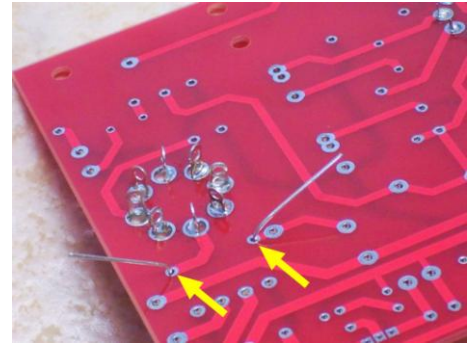
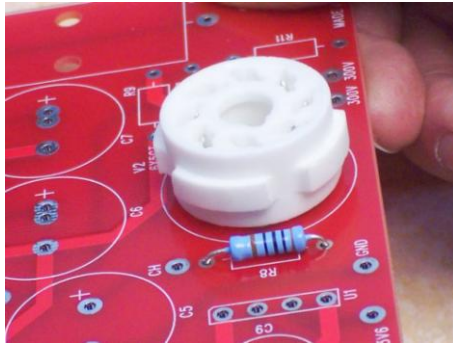
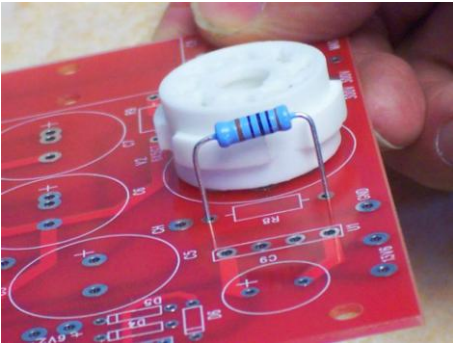

Above shows the installation of the 100R resistor into the R8 position – Bend the legs slightly on the underside to keep the resistor in place.

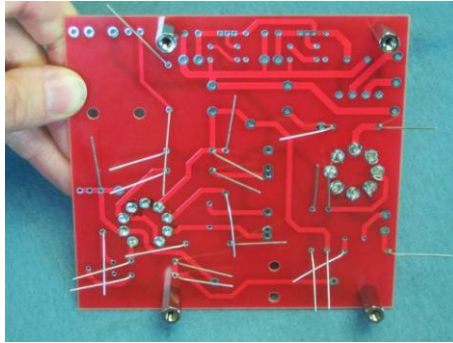

We suggest you install the spacers on the board at this point.

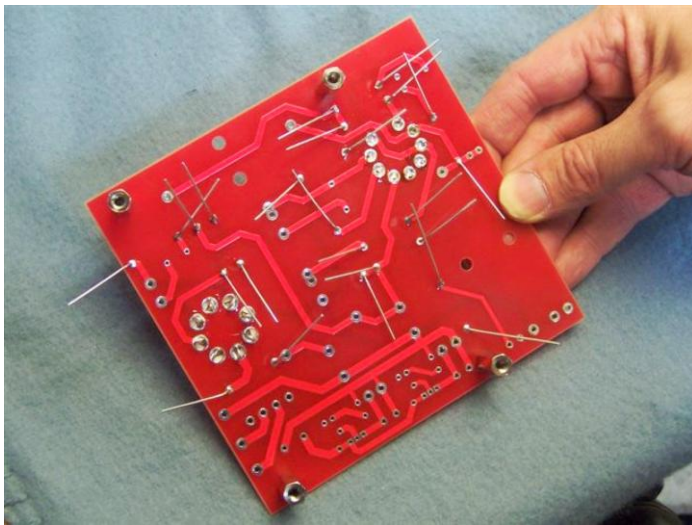

Once you are feeling confident of your resistor installation it is time to solder on the underside of the board.

For first time soldering here are some tips to follow:

1. Clean the tip with a wet sponge after each solder so as not to let resin build up.
2. 'Tin' the tip (i.e. add a small amount of solder to it) just before soldering.

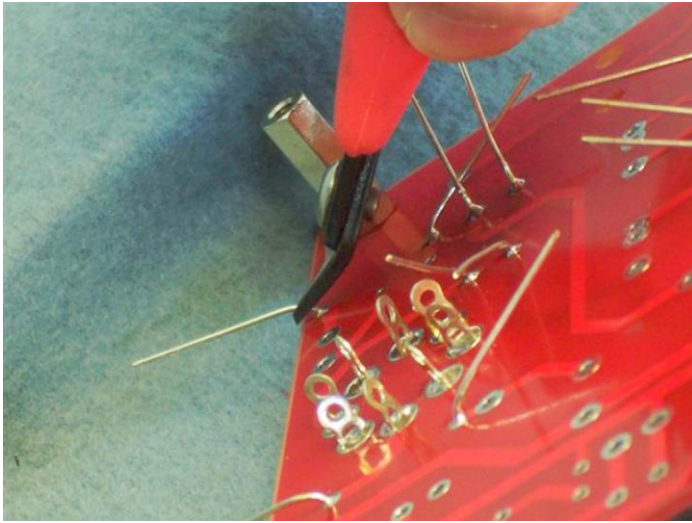

Once the joints have been made, give them a quick inspection and touch up any that look suspicious in any way.

Next step is to clip the leads - you want to do this but be careful not to clip off too close to the board where you endanger the pad - see picture opposite for a good example.

### Installing resistors in the HT ADJUST position

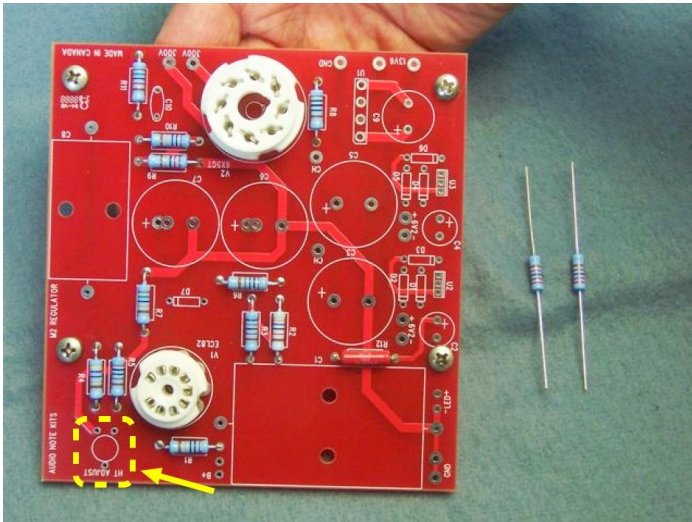

We used to use a little trim pot in this position - but due to its unavailability we are now using a resistor combination to do this.

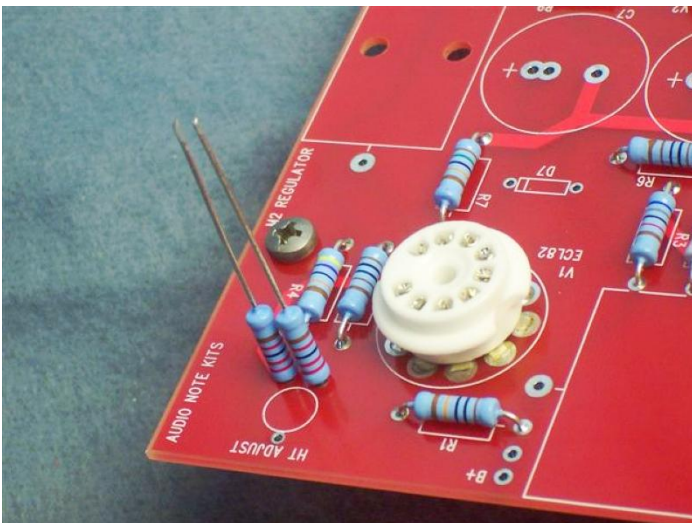
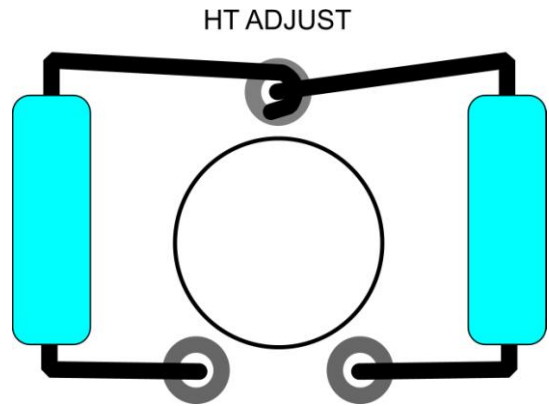

Insert the resistors into position as shown.

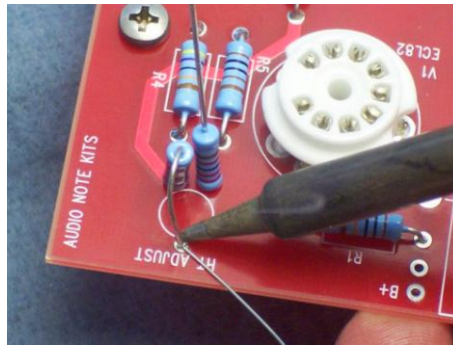
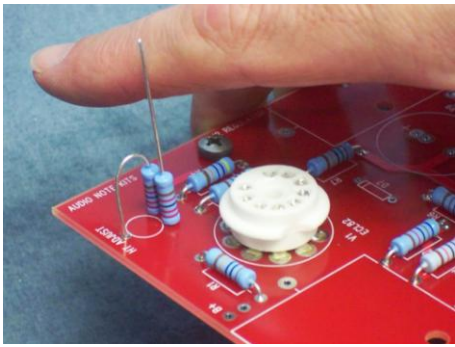

Bend one of the legs over and through the hole in the board as shown - solder into position from the top of the board.

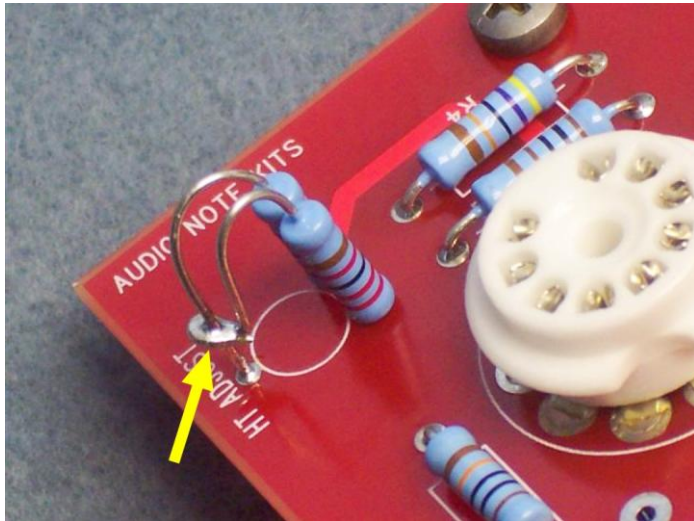

Take the leg of the other resistor and twist it around the leg of the other one as shown opposite.

Here you can see the resistors in position – you will want to solder the two resistors now on the underside of the PCB.

## Zener Diode Installation

Semiconductor Devices	1	3.5W 150V Zener	D7
-----------------------	---	-----------------	----

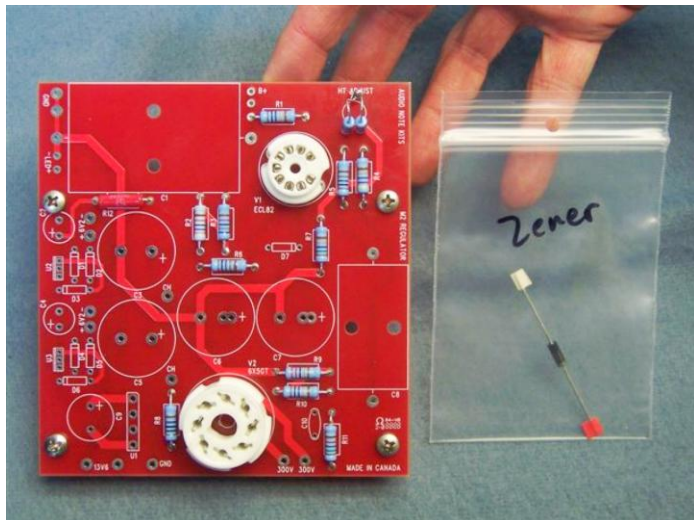

This is a critical part and therefore warrants its own individual bag.

The Zener diode goes into the D7 Position .

You will notice a gray stripe on the zener and you will want to position this to match the stripe on the stencil on the PCB in D7 position.

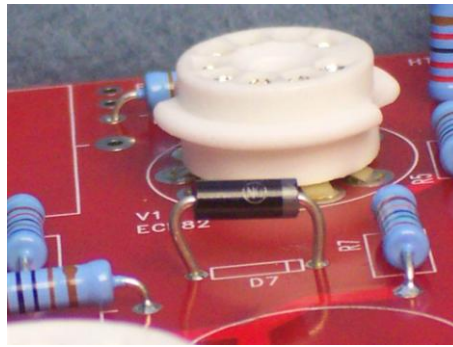
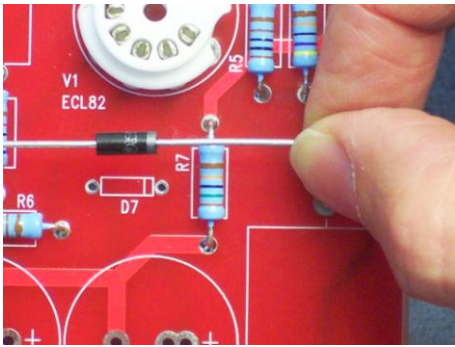

Here you can see the Zener diode installed in the correct orientation.

## Electrolytic Capacitor Installation

Capacitors (Electrolytic)	1	2200uF 35V	C9
<i>Do not install C2 and C4 at this stage</i>	2	22uF 450V	C6 ,C7
	2	68uF 450V	C3, C5

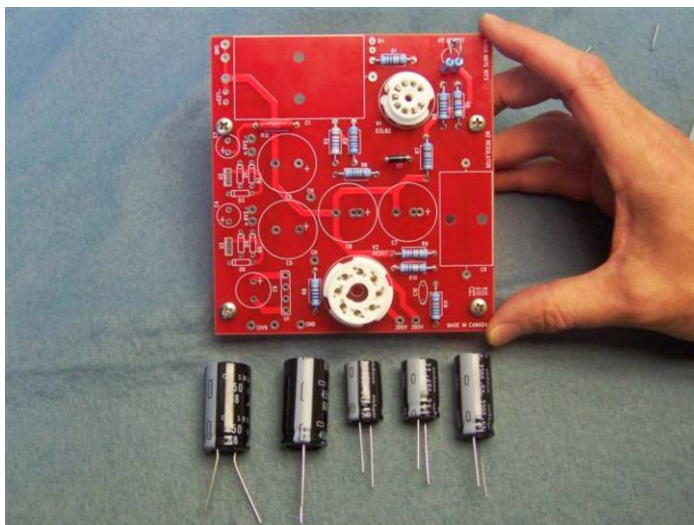

We are now going to install the Electrolytic Capacitors into the power supply Board. Note that C2 and C4 will be installed at a later stage.

**Electrolytic Capacitor Lesson:** An electrolytic capacitor is a device that has a positive and a negative side to it. In other words it **MUST** be installed correctly or it will basically explode. Luckily the modern capacitors have a slow explosion mode that will look like a dragon breathing fire.

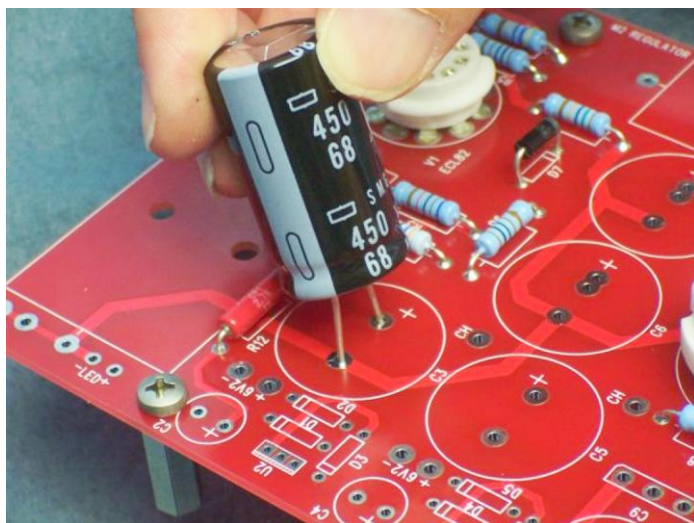

Let's begin by installing C3.

You will notice that the capacitor has some markings on it - a 68 for 68uF, a 450 for 450Volts, and a large strip down one side which signifies the **NEGATIVE** side of the capacitor.

You will notice on the stencil on the PCB that there is a + designator on the board and you will need to orient such that the + side is the **opposite** to the **NEGATIVE** stripe - The electrolytic capacitor also has a longer lead on the **POSITIVE** side.



Here we can see both 68uF capacitors (C3 and C5) correctly installed.

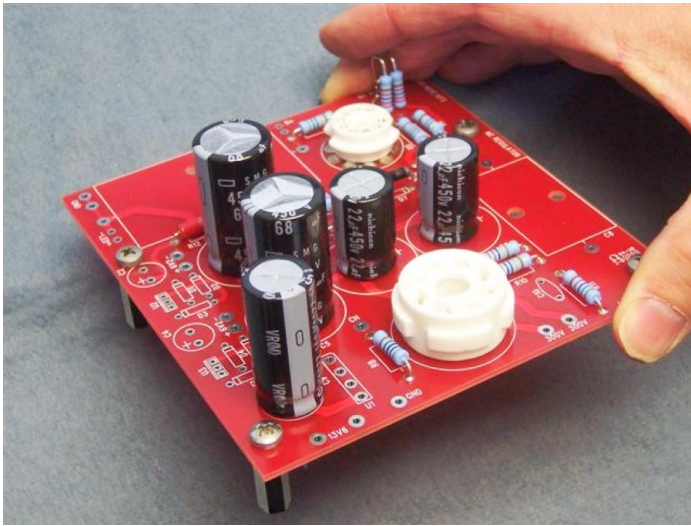

Install the remaining electrolytic capacitors that are required at this stage (i.e. C9, C6, and C7).

You can see these installed in the picture opposite.

## Installing the Bridge Rectifier

Semiconductor Devices	1	KBU6J6A	U1
-----------------------	---	---------	----

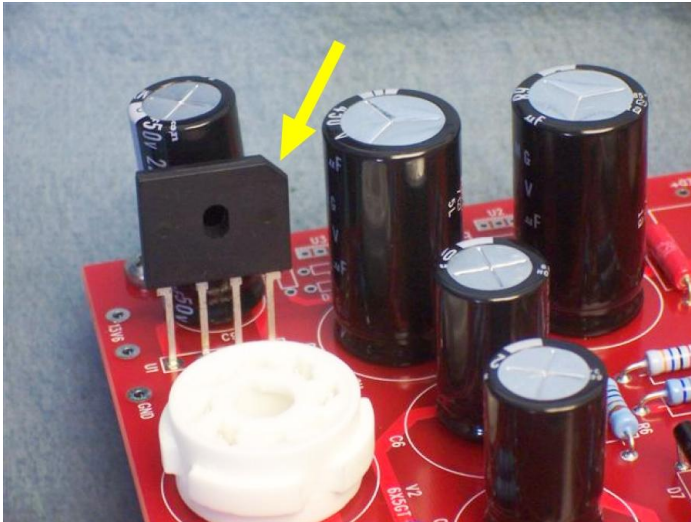

Install the Bridge Rectifier into position in U1.

Note the notch is located facing into the middle of the board - you will also see a corresponding notch stenciled on the PCB.

## Installing the Non-Polarized Capacitors

Capacitors (Non-polarized)	1	Disc 4700uF 3000v	C10
	1	.22uf 600V	C8
	1	.47uF 600V	C1

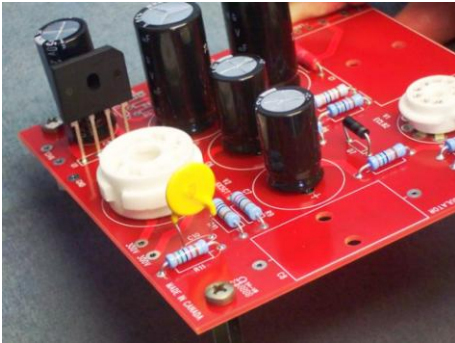

Install in C10 the DISC capacitor – this capacitor is not polarized so it does not matter which direction you put it in.

Now the same for C8 which is called a FILM capacitor and also is not polarized so it does not matter the orientation. You will notice on the .22uF capacitor it designates 300 V~. This means that it is rated for 300V AC which is like 600V DC - well within the range of this power supply.

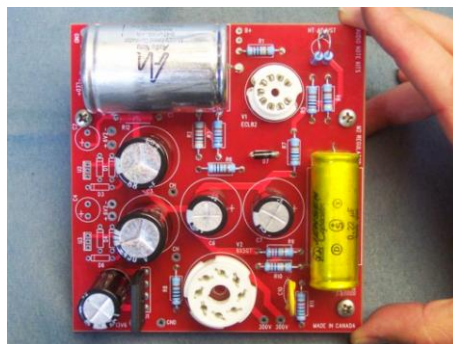
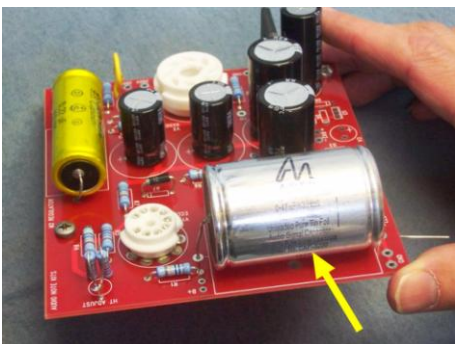

Next step is to install the .47uF AN FILM capacitor into position.

Again this capacitor is not polarized so the orientation does not matter

## Wiring the M2 Power Supply Board

Get your Bag #2 from the Wire Bag as we will be installing the “filament” wires onto the board. We are going to connect several wires to the M2 power supply board – this is easier to do at this stage.

**FILAMENT LESSON:** In order for a tube to function it must be supplied with a Filament Voltage – this is basically a DC (or AC) voltage applied to 2 pins on the tube - this is what makes the tube “light up”. We get these filament voltage supplies from the M2 Power supply board - these twisted wires will be supplying the filament voltage to the tubes on the audio board!

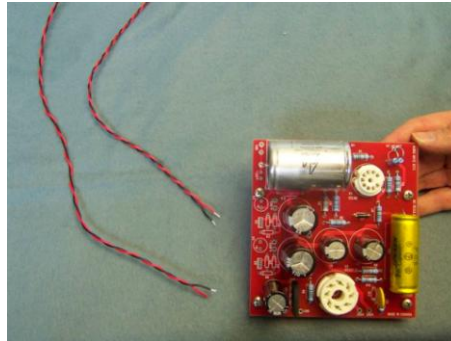

Remove the two long twisted wires from the Bag #2 – We will be inserting these into the PCB from the underside of the board.

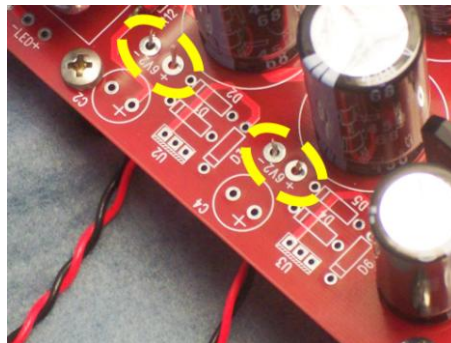
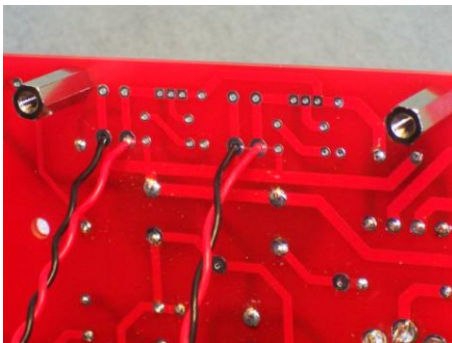

From the underside of the board you can see how the wires are positioned.

On the topside of the board you can see the wires protruding through in the correct location – the red wire will be the + side and the black wire will be the negative.

You will see the +6V2- Note that we use this board in a number of different configurations for both 12v and 6.3v filaments for different kits – the stencil is always marked 6V2.



Solder the filament wires from the top of the board now and you will then want to clip the tops of the wires - be careful not to let them flick up and hit you in the face!

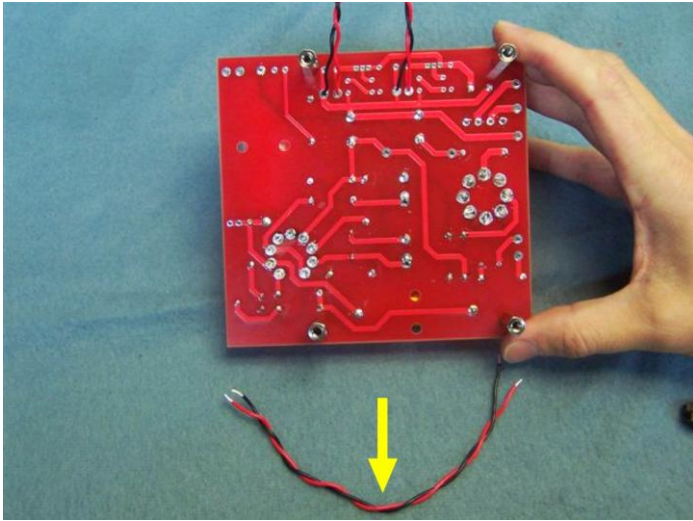

Now take the short wire from BAG #2 - we will be using this to hardwire from the 8-pin valve base to the 9-pin valve base.

**Filament Wiring** - Twist a pair of wires (red and black) to connect between the 6X5 and ECL82. Pin 2 on 6X5 connects to pin 4 on ECL82. Pin 7 on 6X5 connects to pin 5 on ECL82. Finally, pins 2 and 7 on 6X5 connect to the 0-6.3v winding of the TRANS 0103 mains transformer.

The picture below shows the underside of the M2 power supply board.

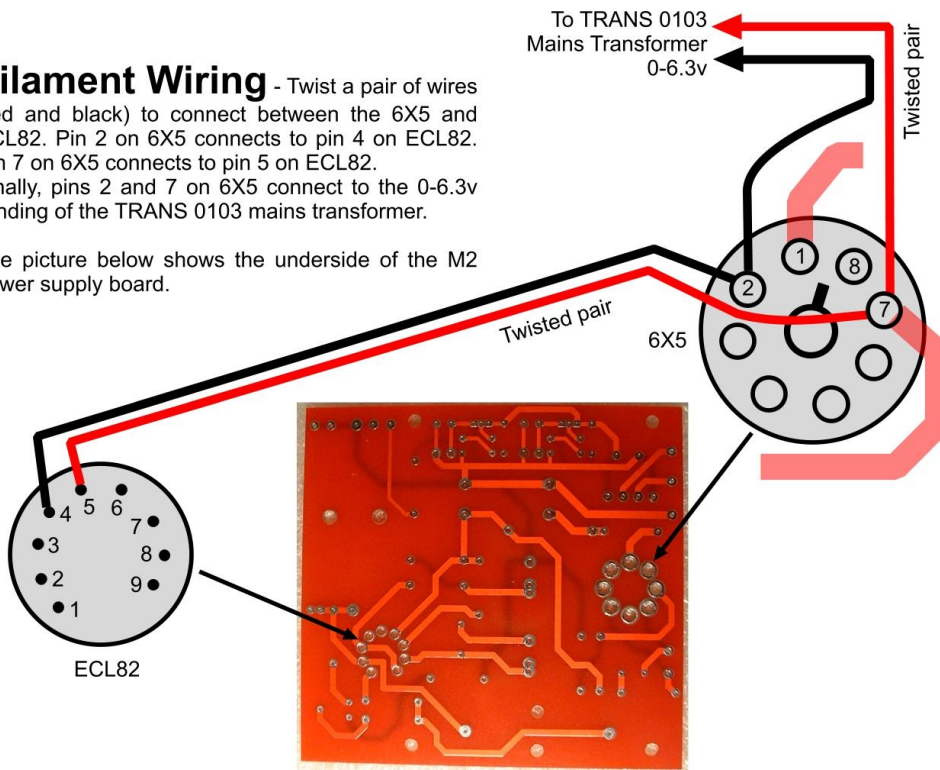

The graphic to the left shows the connections for the twisted wires.

**EXPLANATION:** On the M2 Power Supply Board we will have 2 different tubes - a 6X5 and an ECL82. As explained before, in order for tubes to operate they need a filament voltage - we will be supplying 6.3V AC to both of these tubes. The wire we are installing here is used to "parallel" the 6.3V AC that will be coming from the secondary of the Mains transformer.

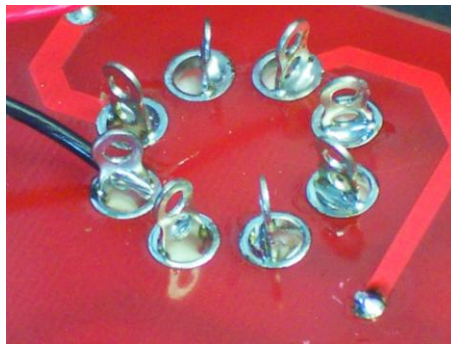
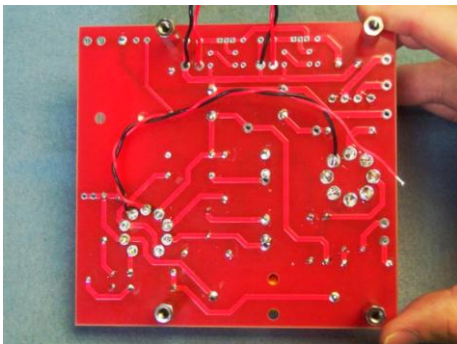

Note in these pictures the twisted wire has been soldered into pins 4 & 5 on the 9-pin valve base.

On the 9-pin valve base note the upper and lower holes through the pins. Connect the current red & black wires to the **lower** hole on the valve pin.

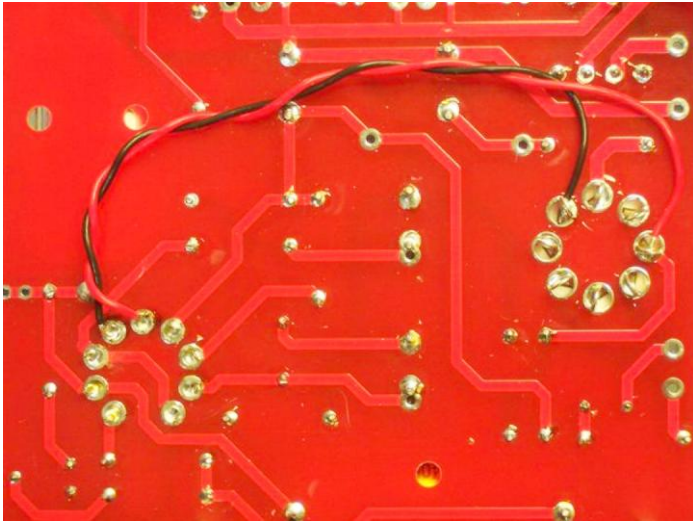

Here is the completed connection of the "parallel filament".

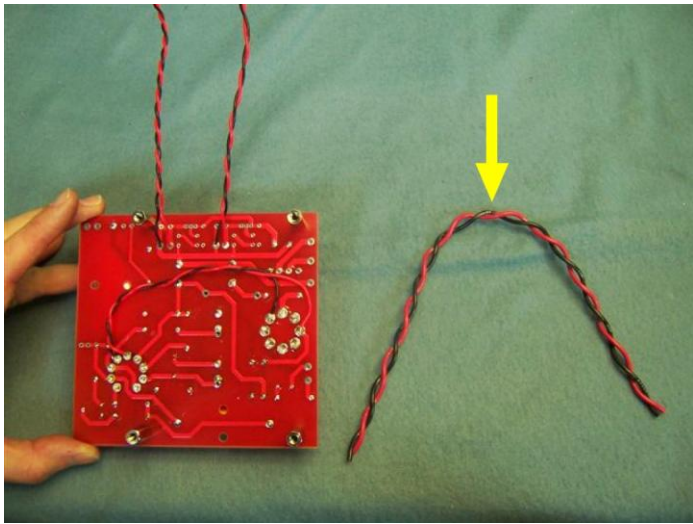

We are now going to install the 6X5 filament wire - this is the THICK black & white twisted wire that is located in Bag #1 of your WIRE BAG.

This is the wire that will connect from the Mains transformer secondary to the 6X5 filament.

Start by stripping about ¼" of insulation off the end of the wire and then tinning the copper ends – these ends will be inserted into the holes on the 8-pin octal base – the same pins we have already connected to with the Parallel filament wire from the last step.

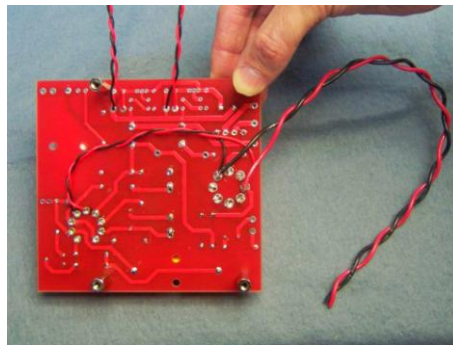
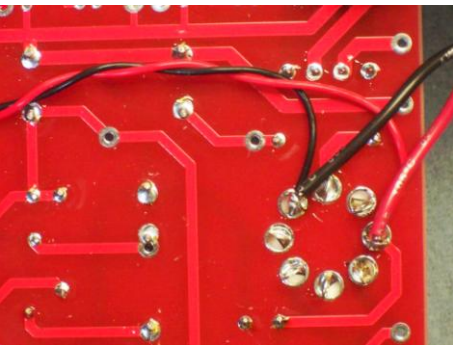

Use the **upper** hole on the 8-pin valve base pin to connect these wires.

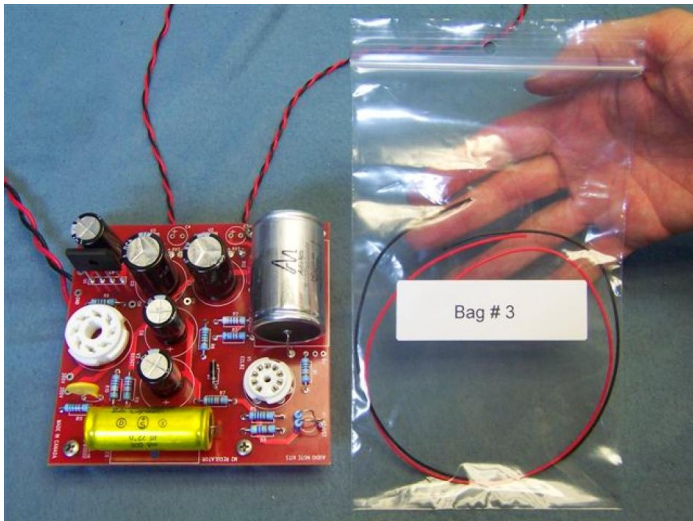

Now get out your BAG#3 from the wire bag and we will install the red and black wires that will be used as the B+ (High Voltage) and corresponding Ground wire.

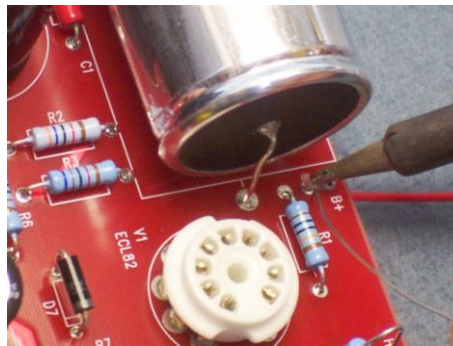
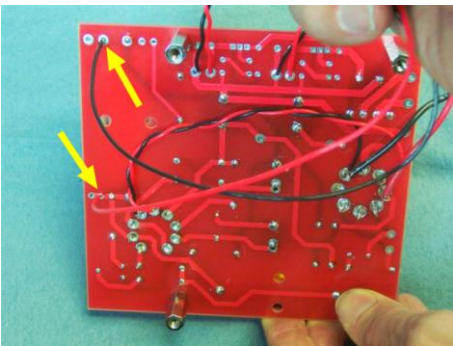

These pictures show the red and black wires installed in the B+ and GND holes on the M2 power supply board. On the right you will solder the red wire on the B+ from the topside of the board - clipping off the remaining lead - and do the same for the Black GND wire.

### Filament Component Section of the M2 Power Supply Board

Semiconductor Devices	4	Zero Ohm Resistors	D1, D2, D4, D5
	2	1N4007	D3, D6

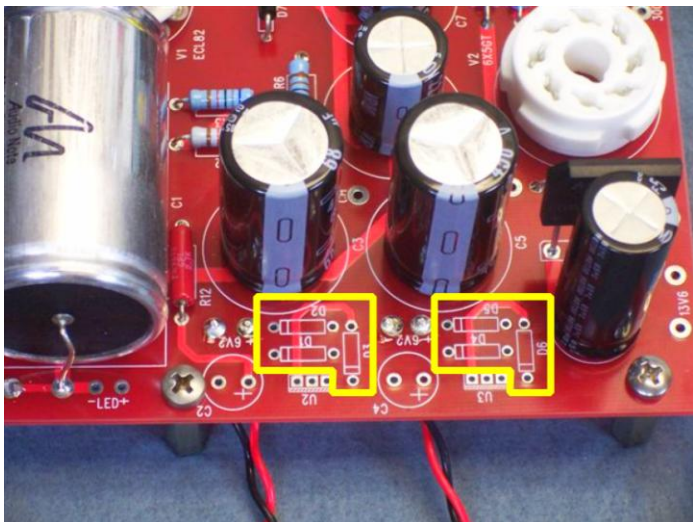

This section controls the voltages that we will be supplying to the analog output board.

Here we are configuring for 12V filament operation (as used in the L3 Line, L3 Phono, and DAC3.1).

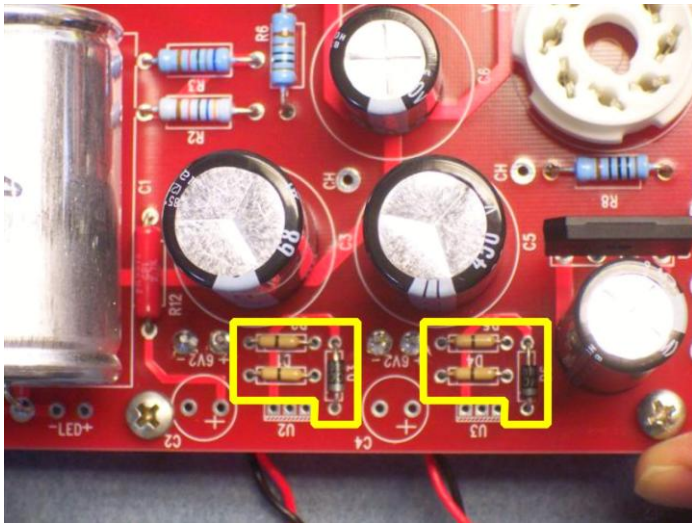

The 1N4007 Diodes are polarized and therefore need to be installed correctly. In the picture above you will note the D3 & D6 designators which shows a bar – this bar lines up with the gray strip on the zener diode – Note how they are correctly installed.

Go ahead and install the zero ohm components into position and the zener diodes.

## Regulator Installation

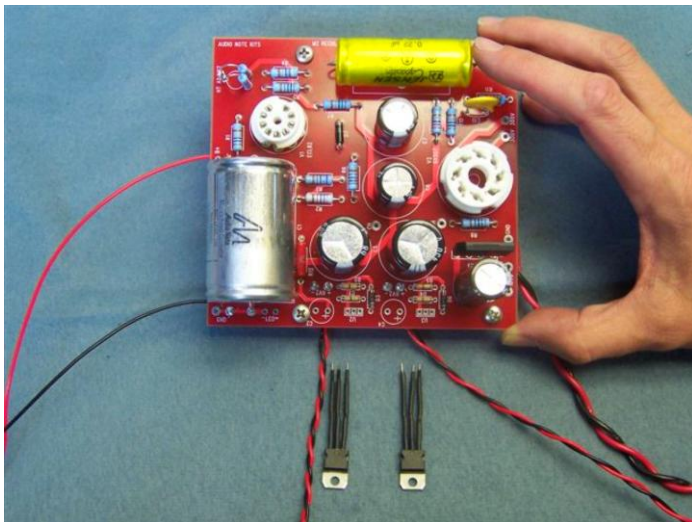

Two regulators have been provided with the kit – these have been specially made to an exact length by AudioNote Kits. They use a solid core wire so that it is easy to position on the board through the tiny holes – Read this section before doing any soldering!

**IMPORTANT:** Note the position of the regulators in the pictures below.

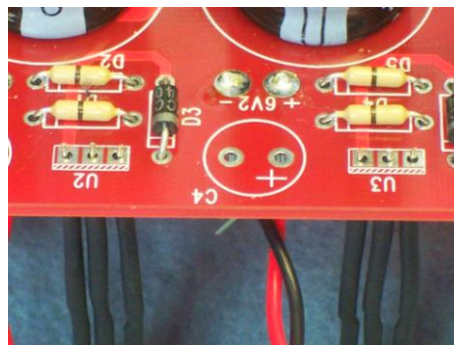
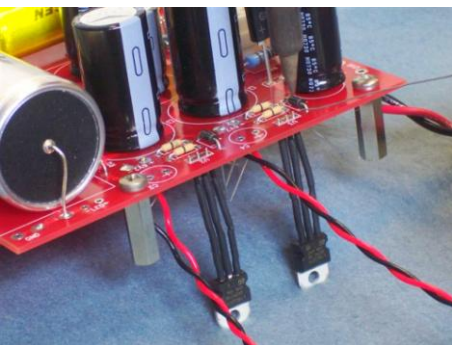

Place the regulators into position as shown opposite and below.

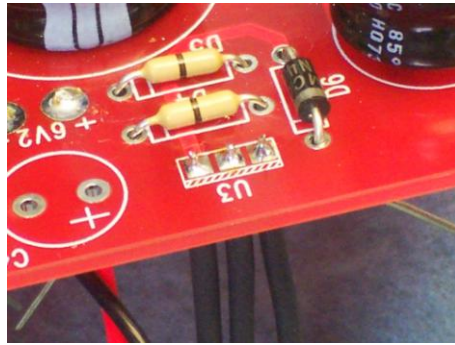
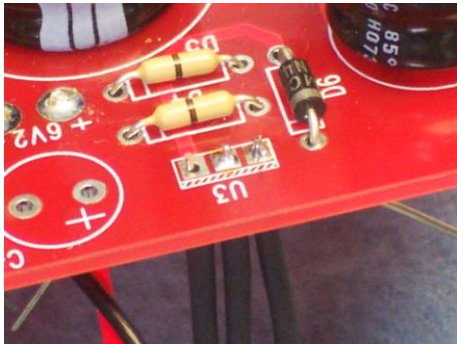
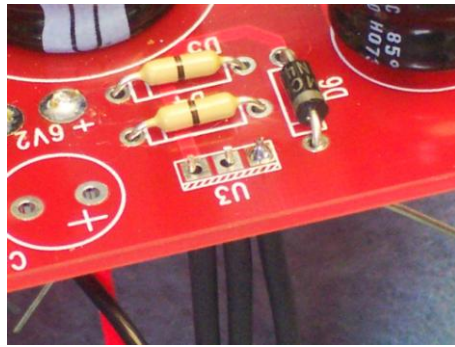
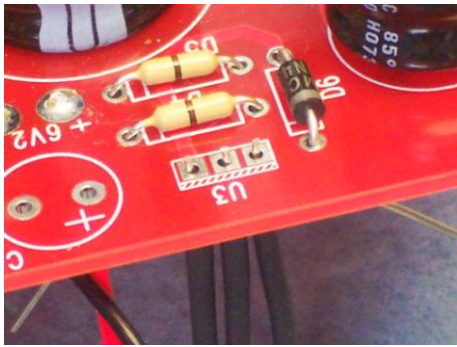

The pictures above and opposite show a successfully configured regulator.

Once these components are in place you can then install the remaining two electrolytic capacitors (C2 and C4).

### Installing the LED Harness



Take the LED Harness from your M2 PS bag and you can solder it onto the board as shown opposite. Solder from underside of the board.

### Remaining Wire Connections



Take the remaining thick Black & White twisted wire from the BAG#1 and solder it to the 13V6 locations on the PCB.

It does not matter which is red or black as it is an AC voltage signal.

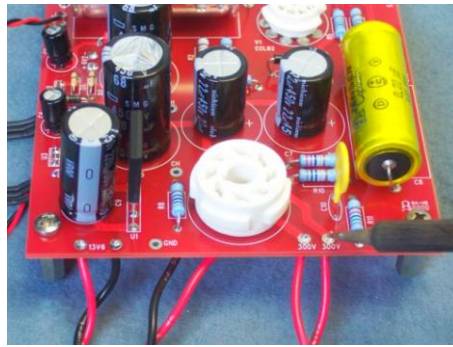
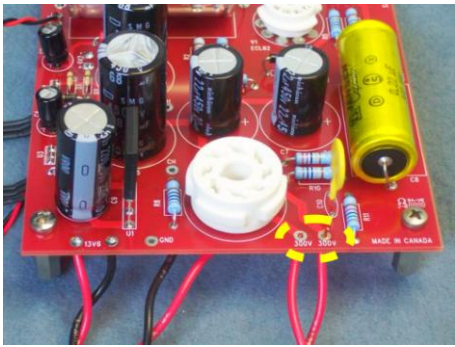

Then take the twisted thick RED wires and connect these to the 300V 300V on the PCB.

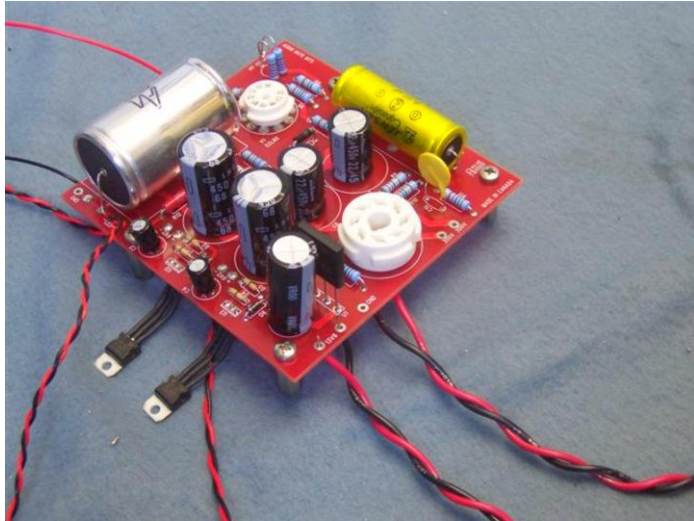

The picture opposite is what your M2 Power supply board should now look like!

## Installing the Heatsink

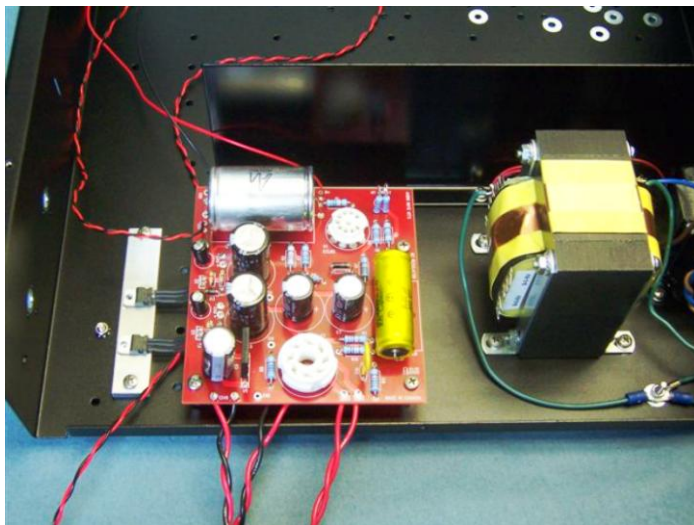

Feel free now to “place” (do not screw in) your newly assembled board into position in the chassis.

Now install the metal heatsink under where the regulators will sit. This must be firmly attached to the chassis.

One more step and then time for a coffee break on a job well done!

## Installing the Choke Wire

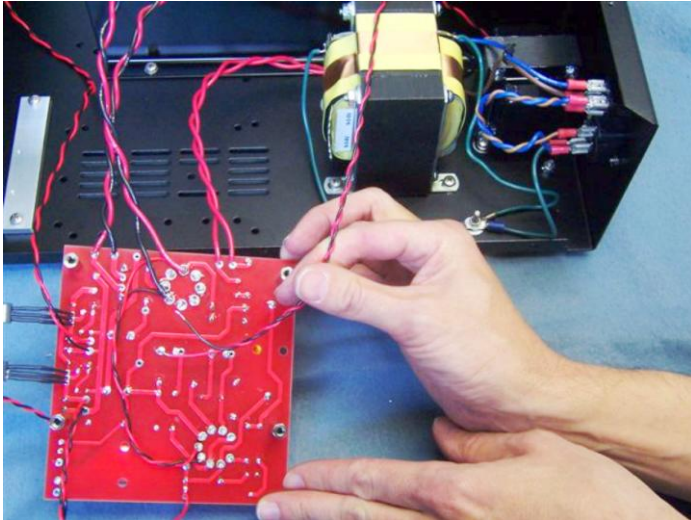

The Black CHOKE that is located at the rear of the chassis and has a red and black wire. you will want to twist these wires by hand and feed them along the shield towards the M2 PCB.

We will now solder these wires directly to the underside of the PCB – You will notice that on the **top** of the PCB there is marked “CH” in two locations – these are the holes that the CHOKE will be connected to – Flip over the M2 PCB and locate the holes on the under side

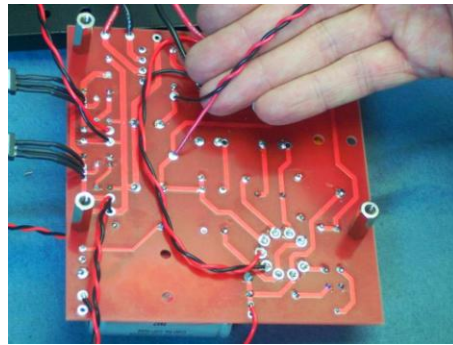
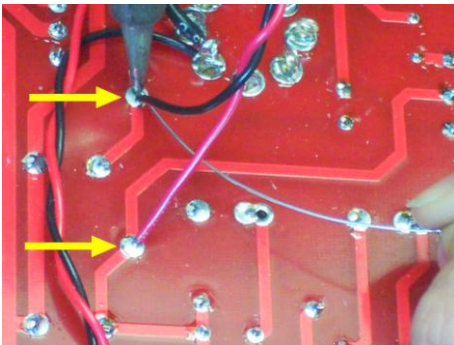

You will want to cut the choke wires to the correct length, leaving a nice amount of slack. Trim the insulation from the ends and tin the wires if you see fit. Then insert the wires from the underside of the board - no polarity for red or black so you can follow along with the pictures opposite.

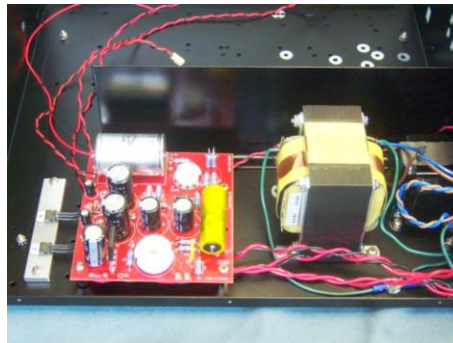
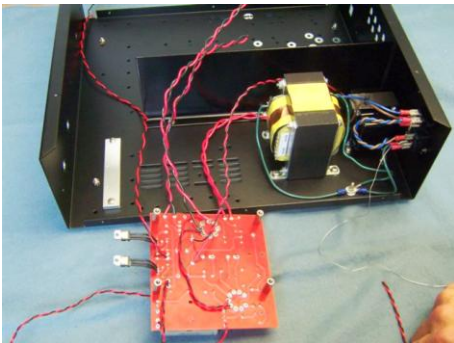

Now that the choke wires have been soldered to the board, you can now place the board back into position.

Well done – we will be soldering connections to the Mains transformer in the next session!

## Inter-wiring to the Mains Transformer

I would suggest at this stage to REMOVE the black shield so that we can work on this side of the chassis.

The following graphic shows the wiring between the M2 PCB and Mains Transformer. Note that the 'second' transformer is simply another view of the same mains transformer.

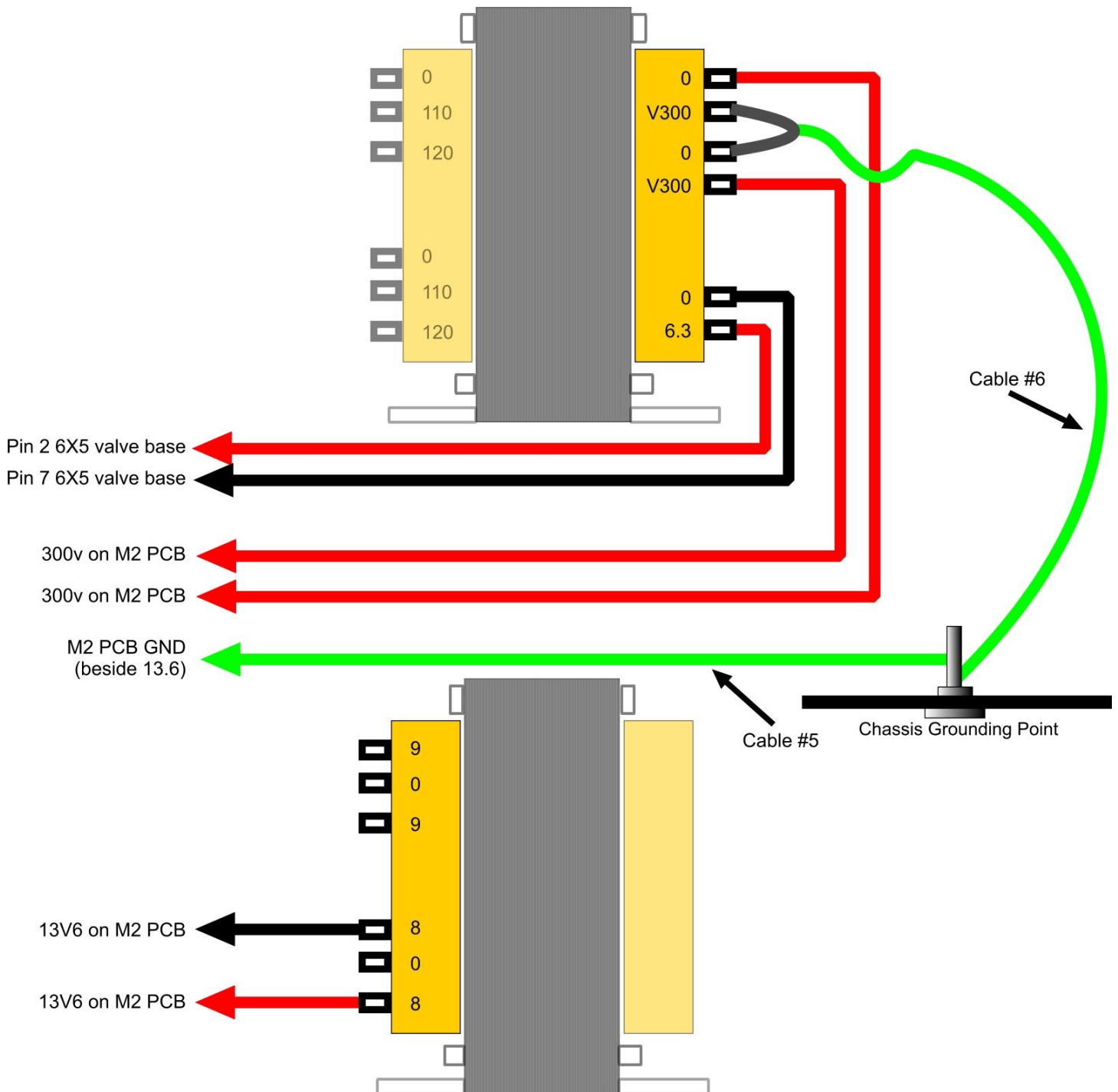

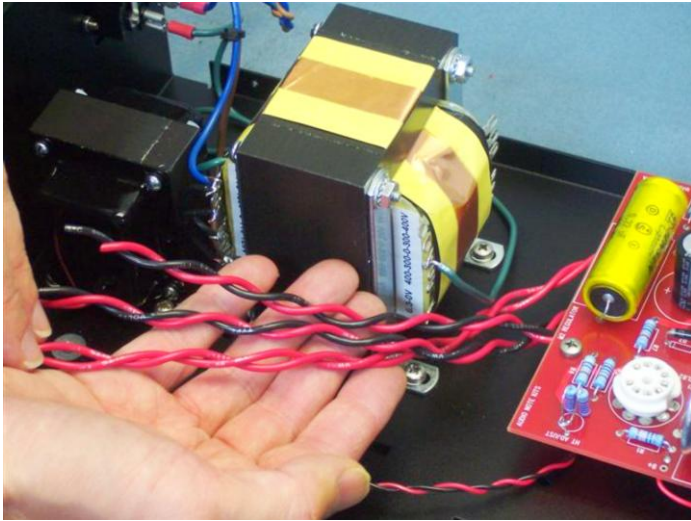

We are now going to take the 3 pairs of twisted wires that are already connected to the M2 Power Supply Board and connect these directly to the SECONDARY of the Mains transformer.

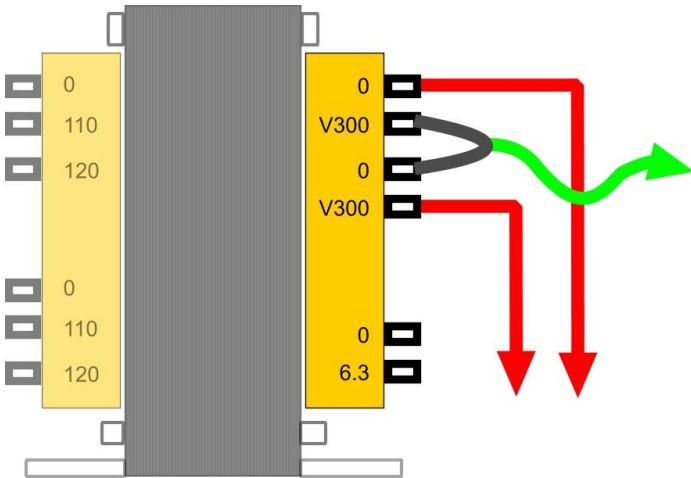

Start by taking the RED / RED twisted pair and trim to a good length and then solder to the '300' lugs on the Mains transformer. I would suggest stripping the insulation off the end of the red wires and tinning. Then place the tinned lead through the lug on the Mains transformer and then apply solder – it is not necessary to twist the lead around the post.

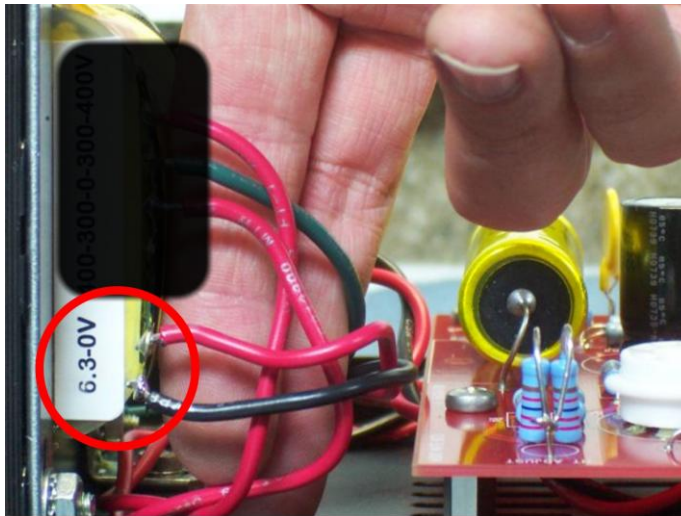

Next step is to take the **Red/Black** twisted wire that is connected to the 8-pin octal valve base.

For the 6X5 – this is the filament wire which will be supply 6.3V to the 6X5 and ECL82 tubes on the M2 power supply.

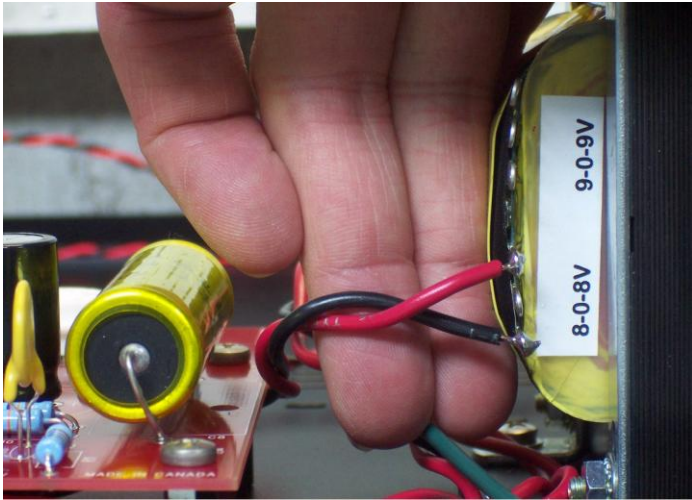

The third pair of wires is the Red/Black twisted pair that is connected to the 13V6 on the M2 power supply board.

Note that the 0 tap is not used here.

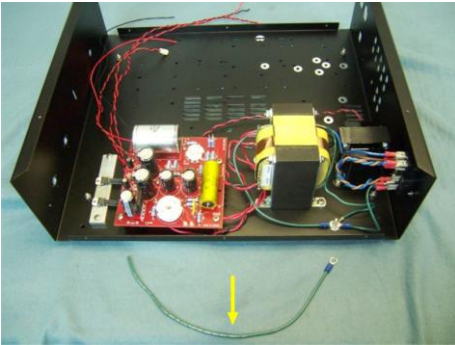

The last wire for hookup in this section will be the long green wire with the GND lug on one end found in your IEC Kit Bag- Secure the GND lug end on the M4 screw in the chassis and trim and solder from the top of the board the green wire into the GND hole located near the 13V6 pads on the M2 power supply Board.

Now review your connections made in this section using the graphic opposite and wiring table below.

Wire	M2 PCB	Mains Transformer
RED / RED	300v 300v	0(1) V300(2)
RED/BLACK	13V6 13V6	8 8
RED/BLACK	Pin 2 & 7 6X5	0 6.3v

Check that you have made the connection between the chassis GND lug and GND on the M2 PCB.

Check that you have made the connection between the chassis GND lug and 0 on the mains transformer (i.e. the 0 between 300 and 300).

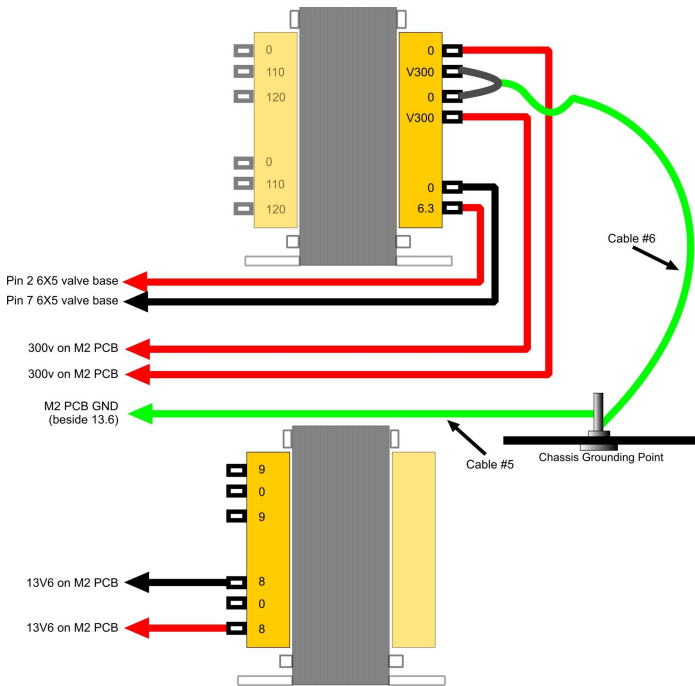

## Securing the Regulators to the Heatsink

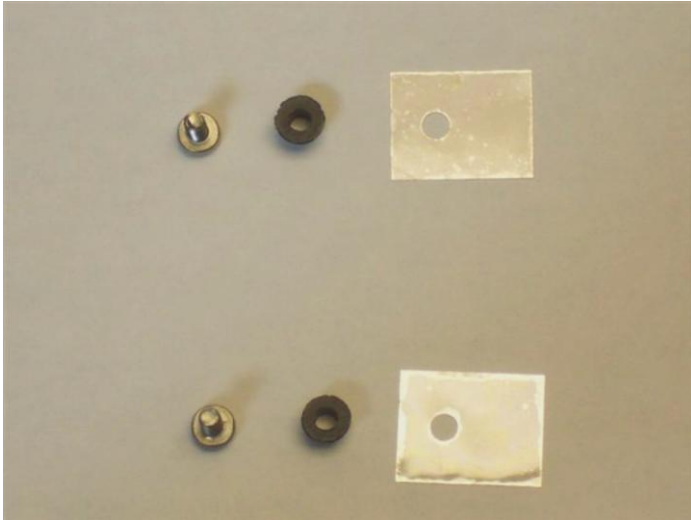

We are now going to secure the regulators to the Heat Sink that is installed in the chassis.

The picture opposite shows the parts that are necessary to do this.

**EXPLANATION:** It is ideal to electrically isolate the regulator from the ground on the chassis (i.e. the heatsink) – this way the regulator is floating – we do this with our little insulation kit which consists of a mica layer and a plastic insert. You can get these from the Hardware Bag marked Heat Sink.



Begin by taking one of the mica washers and laying it on the heatsink as shown in the left-most picture.

The plastic insert should be fitted onto the screw as shown in the central picture.

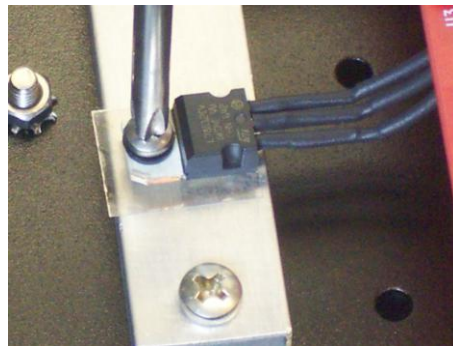
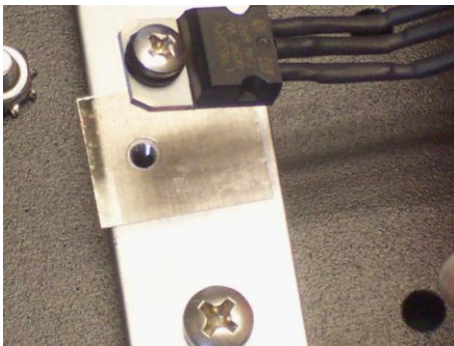

I would suggest that you line up the mica strip with the hole in the heat sink and install the screw and plastic insert into the hole in the regulator.

Then gently screw the regulator into the heat sink- the mica piece may try and move so just gently ease it back into position.

Repeat for the second regulator.

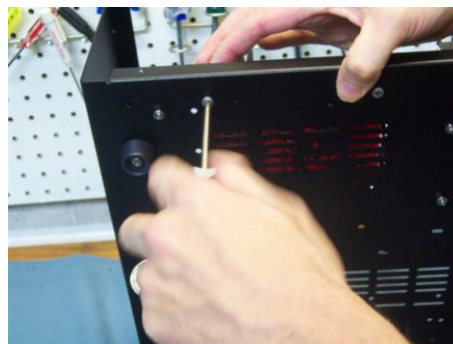
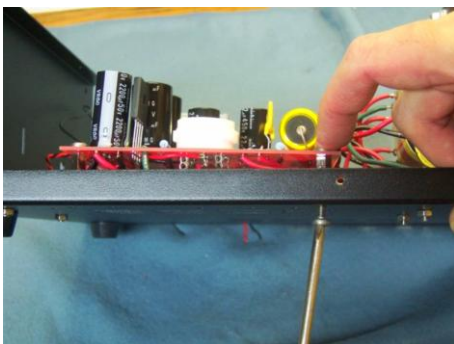

At this point you can secure the M2 power supply board to the chassis with one or more of the M4 screws provided.



That completes our assembly of the M2 Power Supply Board.

Feel free to re install the shield back into position or you can wait until nearer the end of the kit build if you prefer.

# Section 4: M2 Power Supply Testing

## Preparations

### Fitting the Mains Fuse

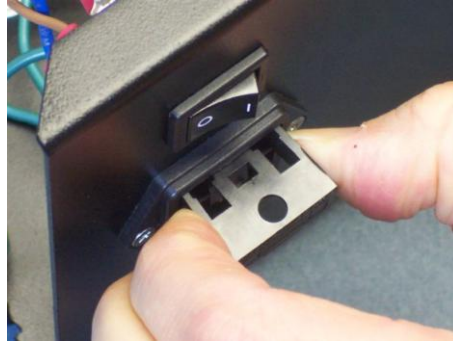
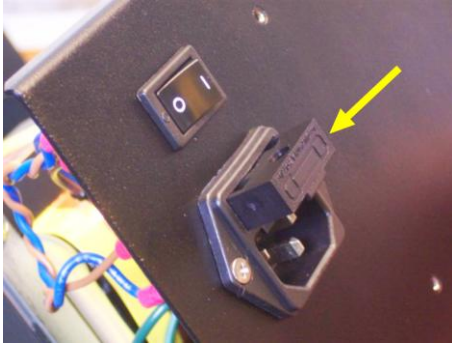

In this section we are going to electrically test the power supply.

Start by installing a 1A Slo Blo fuse (IEC BAG) into position as shown.

Use a screwdriver or flat edge or your fingers pull the Fuse holder out - you will need to squeeze to completely remove it.

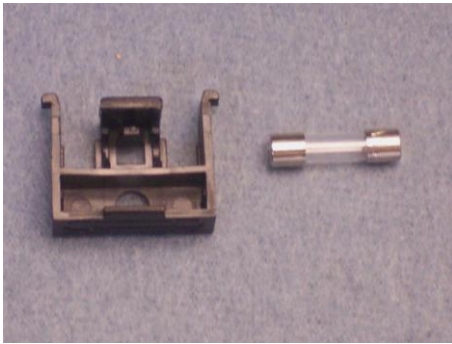

Insert the fuse into the holder as shown opposite.

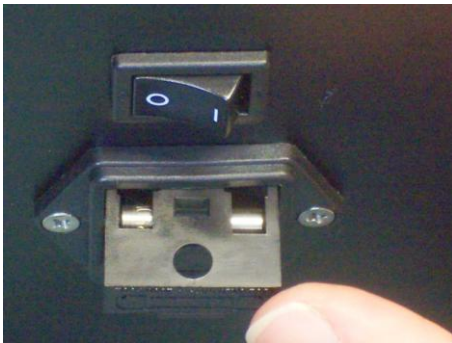

With the fuse installed into the holder insert back into the IEC plug.

With the Fuse installed we are ready to do some testing!

READ the entire remaining section first before taking any actions!

## Installing the LED Indicator

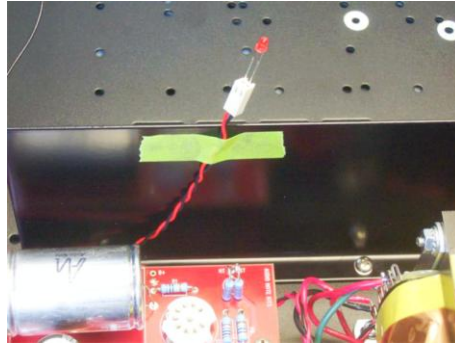
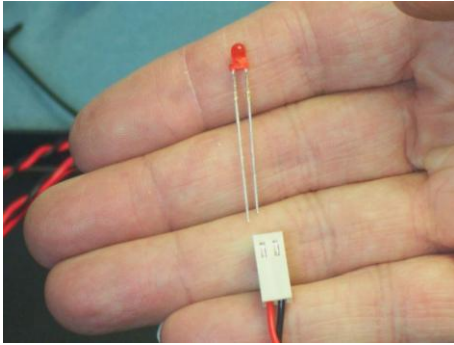

The LED on the M2 Power Supply Board will be the first indicator that we have power – I would suggest just taping the LED – make sure the metal leads of the LED are not touching any other circuitry or chassis – Note the Led has not been pushed in all the way.

Also note that the LED will only work when inserted the correct way around.

## Installing the tubes

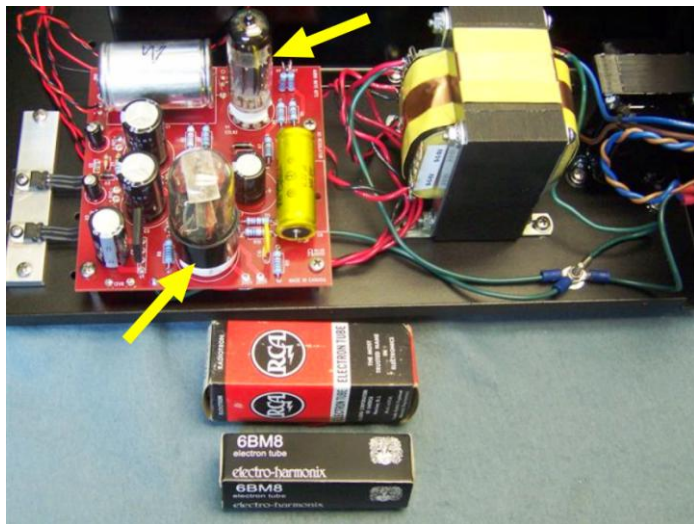

Let's install our tubes into the board – the supplied 6X5 in the 8-pin valve base and the ECL82 (or 6BM8) in the 9-pin base.

## Tidying Up

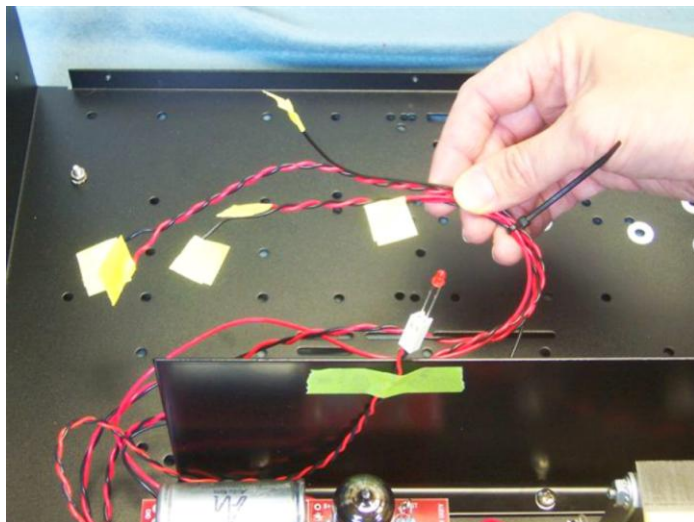

Seeing as we have a number of loose filament and HT wires coming from the PCB, I would suggest taping the ends to make sure that they do not short with one another when we go to test with power!

## Ohm Check

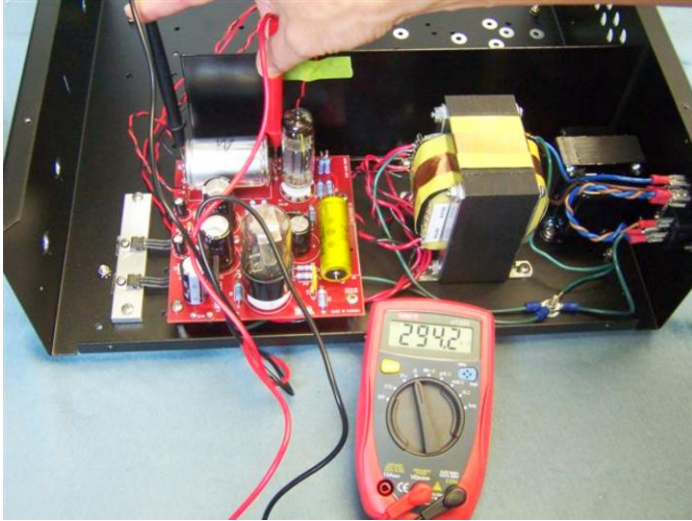

**EXPLANATION:** There are a number of terms that we will be using in this section that we should be familiar with – the HT or High Voltage or B+ is all the same thing – this is the HIGHEST DC voltage in the circuit typically and is the voltage that we will be supplying to the Tubes in our audio signal path.

THE UNIT IS STILL OFF AT THIS POINT

If you have a Multimeter set it to OHMS and measure the resistance from B+ to GND on the M2 Board – you can see from the picture opposite the approx location on the board to find these 2 points. You should see a reading in the 300K ohm range – this is a good sign – if you have a very low ohmage then there could be a problem and you may want to contact us first.

## Electrical Testing



Take a power chord and plug in the unit but make sure the amplifier is off.

Before the first power on we suggest the following steps:

1. Make sure that you have a quiet environment when you are turning on for the first time – that way if there is a problem with the circuit you will be able to see & hear a crackle or a vibration or hum etc. if there is any.
2. If you have a Variac then it would be useful to use it so you can power on slowly and check DC voltages – If not we will just turn on.
3. Press the Rocker switch such that the 1 is pushed flat against the chassis.
4. Observe the LED light turning on and also look for glow from the tubes.
5. Get ready to switch off immediately if anything goes wrong.
6. Get your voltmeter ready – you will want to perform a High Voltage check.



First measure from B+ to GND on the M2 PCB (use the ground point closest to the LED section).

You should read approximately 260v DC.

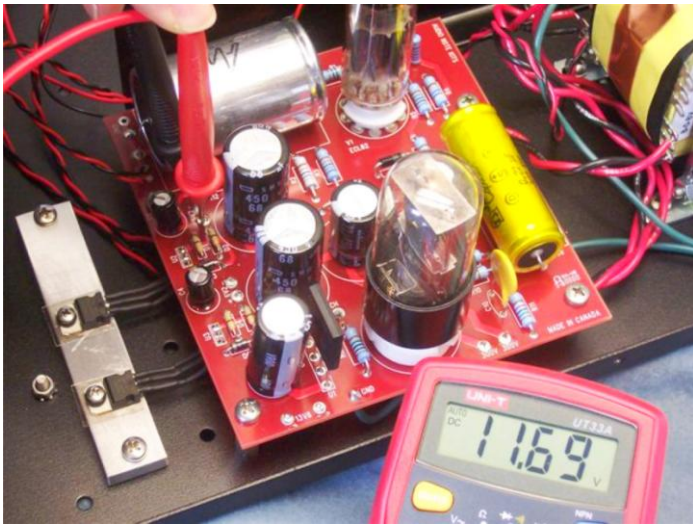

Now measure the filament voltages - these are the connections labeled +6V2- on top of the PCB.

These should be approximately 12v DC.

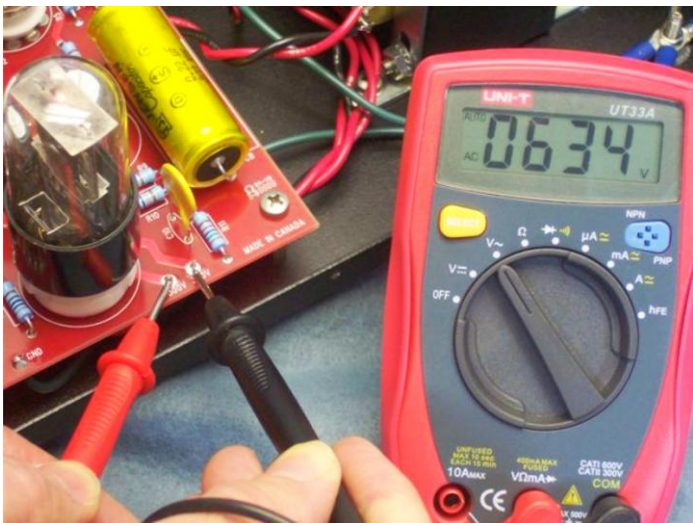

If there is a problem with any of the above voltages, switch to AC volts and measure the 300 300 points on the M2 PCB – you should get somewhere over 600V AC.



While in AC mode measure the 13V6 pads on the M2 PCB – We have 8 0 8 taps which should give us roughly 16V AC.

## Voltage Check Summary

### DC Voltage Checks

Location	Approx Reading
B+ to GND	260v DC
+6V2-	12v DC
+6V2-	12v DC

### AC Voltage Checks

These are optional if DC voltages are correct.

Location	Approx Reading
300 300	>600v AC
13V6 13V6	16v AC



If you have correct voltage readings on the M2 Power Supply then Congratulations are in order and you have completed the first half of the kit.

Feel free to contact us if you have any problems with your power supply or have any questions up to this point [audionotekits@rogers.com](mailto:audionotekits@rogers.com)

Also feel free to give us an update that things are going according to plan.

# Section 5: Digital Power Supply PCB

In this section we will be building, installing and testing the Digital Power Supply PCB that is used in the DAC2.1 and 3.1 kits.

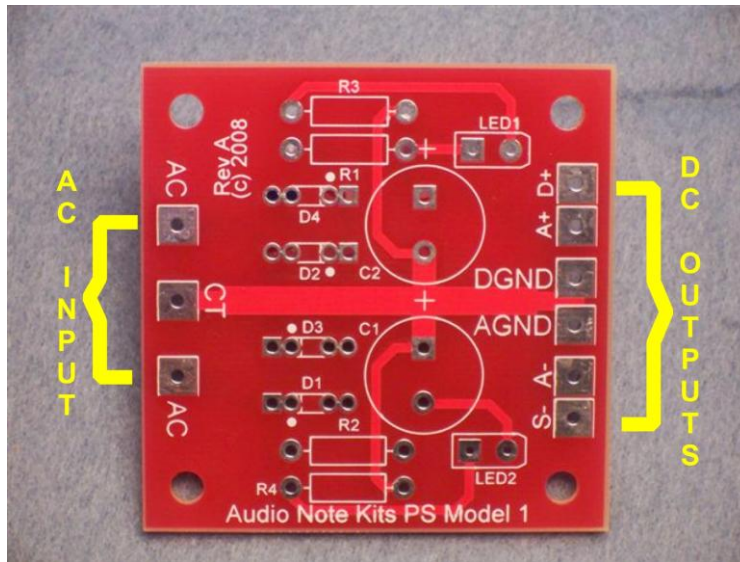

**EXPLANATION:** This small board receives an 18V AC signal from the 9-0-9 taps on the Mains transformers and converts it to several DC voltages that are required by the DAC board. The outputs are A+ - AGND - A- , D+ and DGND.

## Parts List

Category	Quantity	Part	Designator
Capacitors (Electrolytic)	2	4700uf 16V	C1, C2
Resistors	2	1K0	R3, R4
	2	4R7	R1, R2
Semiconductor Devices	4	Schotkey Diodes	D1, D2, D3, D4
	2	L.E.D's	LED1, LED2

## Construction

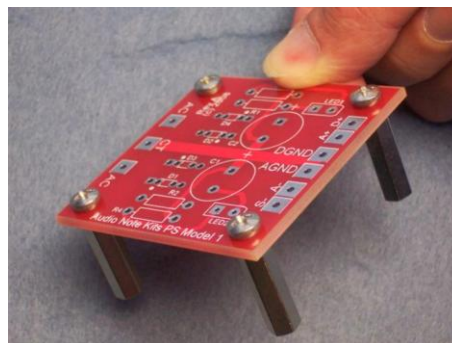

Start by installing the 4 spacers provided. This will make it easier to work with as we install the components onto the board.

If you are an advanced builder we suggest you read through this section completely and then proceed with your build from the parts list – otherwise we suggest you work through each step in the order suggested.

## Installing the LED's

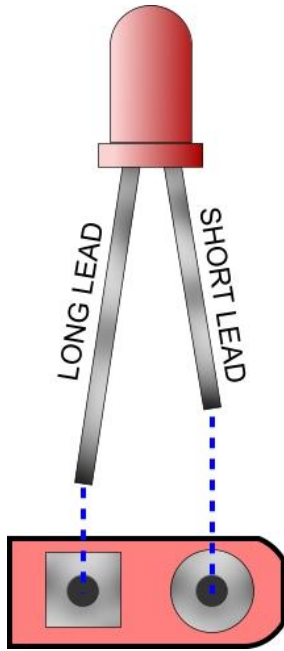

Install the LED's into the LED1 and LED2 positions.

You will notice a square end on the stencil and a rounded end – **Insert the LONG lead of the led on the SQUARE end.**

## Installing the Capacitors

Capacitors (Electrolytic)	2	4700uf 16V	C1, C2
---------------------------	---	------------	--------

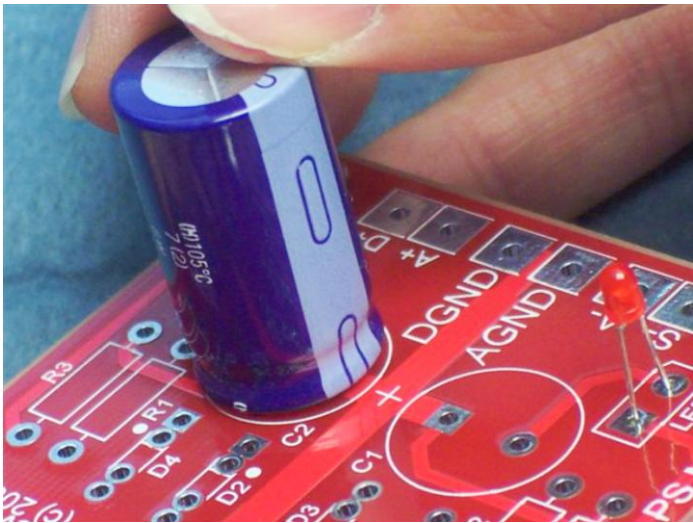

Lets now install the 2 Electrolytic capacitors in the board.

The stencil on the board for each capacitor is a circle with a + sign beside it.

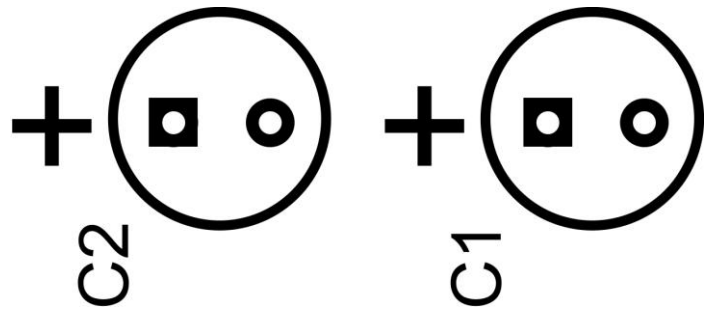

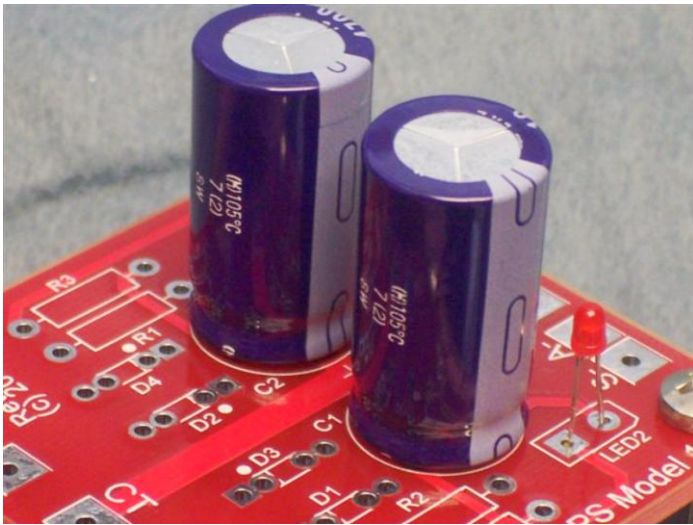

Note that each capacitor only has the POSITIVE side noted – You will have to locate the Stripe on the capacitor as shown above and insert correctly – Don't be confused by the two caps close together.

The picture opposite shows the capacitors correctly installed.

## Installing the Diodes

Semiconductor Devices	4	Schotky Diodes	D1, D2, D3, D4
-----------------------	---	----------------	----------------

**NOTE:** This board has been designed to accept either standard diodes or Schotky diodes (fast recovery diodes). Schotky diodes are supplied with the kit but we will also show how to install standard diodes.

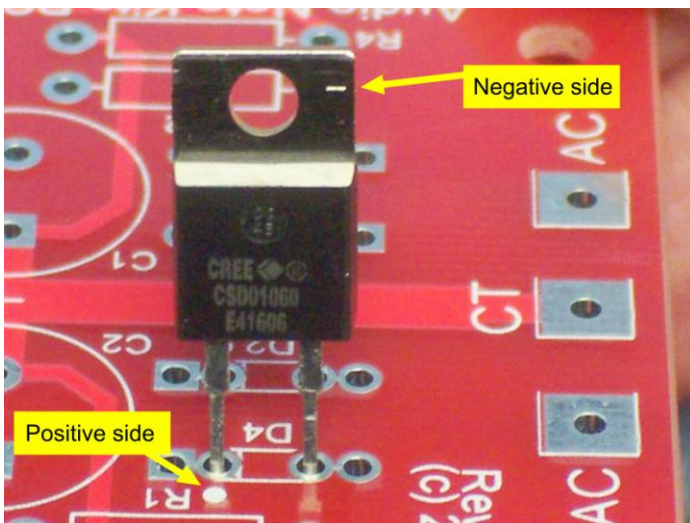

### Schotky diode Installation

For correct installation of the diode shown you will notice the – sign on the top of the DIODE case that denotes the negative side. Also note the white DOT on the board noting positive side.

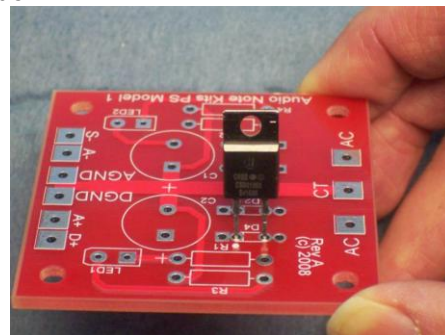

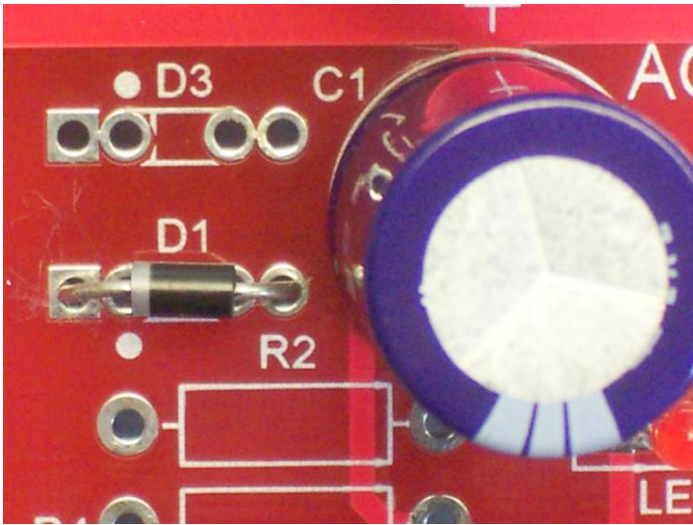

### Standard Diode Installation

Opposite is a picture of the standard diode inserted – you will want to line up the gray stripe on the diode that denotes the positive side and position it where the White Dot is.

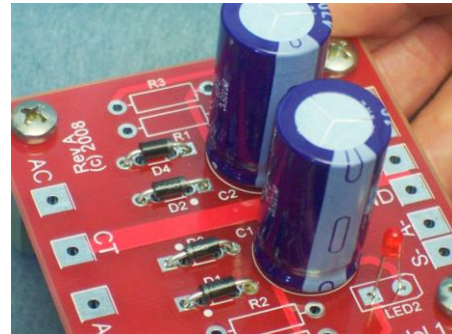

### Installing the Resistors

Resistors	2	1K0	R3, R4
	2	4R7	R1, R2

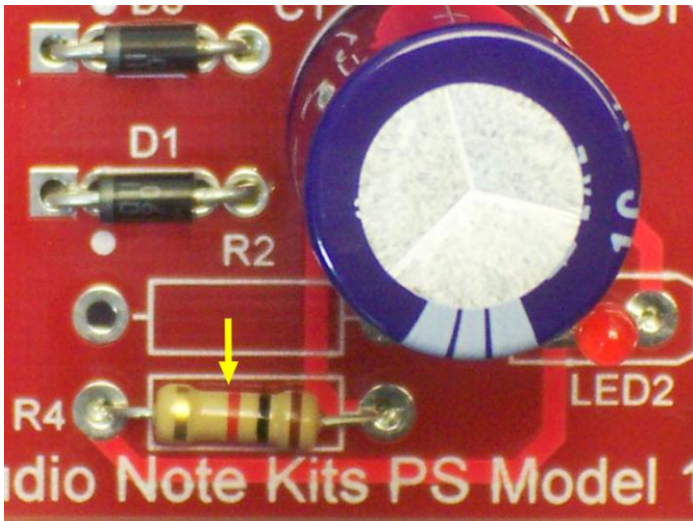

Install all four resistors into their correct positions. These pictures only show R3 and R4.



## Board Installation and Wiring

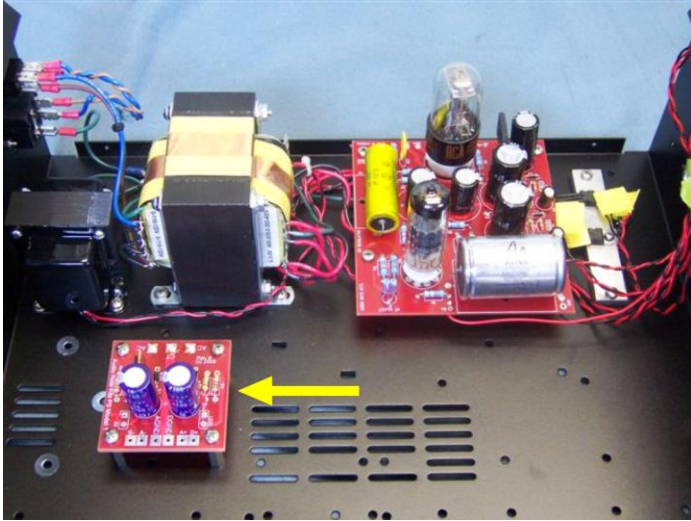

Position the Digital Power Supply board into the chassis as shown with the DC voltage side (AGND DGND etc.) positioned away from the Power Supply.

BE SURE THAT THE KIT IS NOT PLUGGED INTO THE WALL at this point.

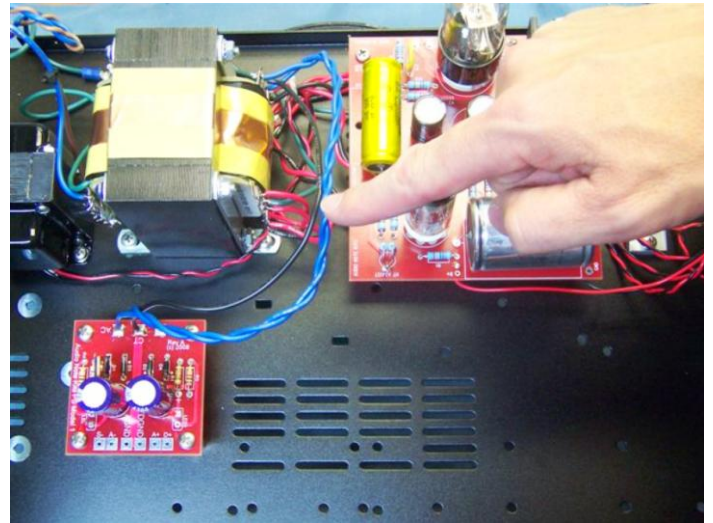
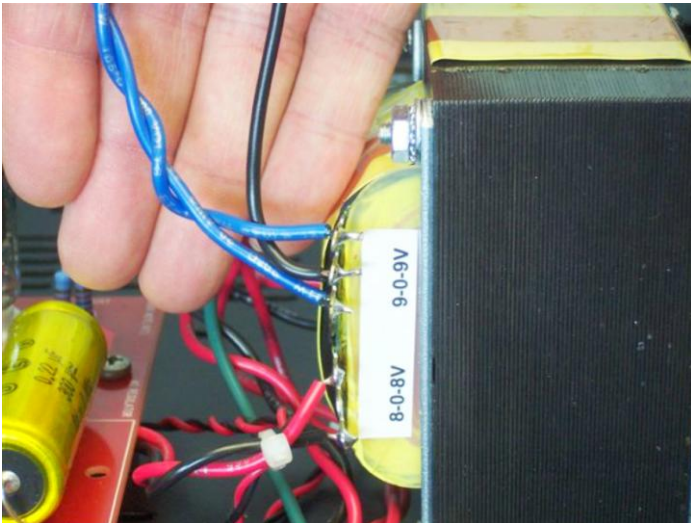

Take the prepared twisted blue wire and locate the 9-0-9 taps on the Mains transformer secondary. Then strip, and tin the blue wire and solder to the 9 & 9 taps – These blue wires then come around the transformer and connect into the AC pads on the power supply board.

Take a black wire and connect the 0 tap from the Mains transformer to the CT pad on the digital power supply board.

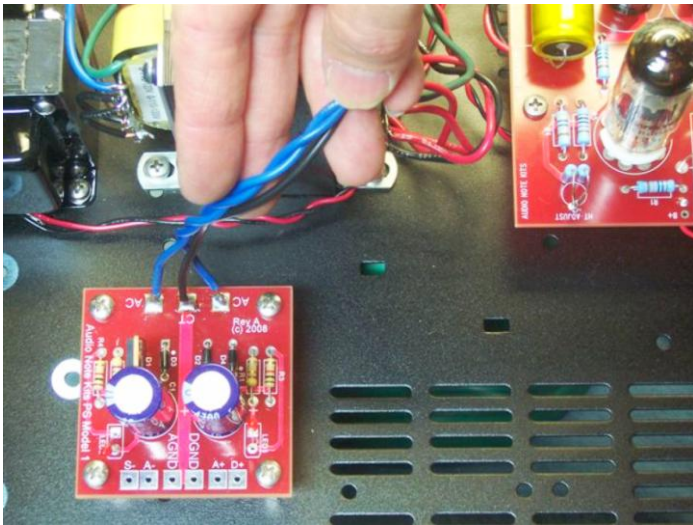

You should now have 3 wires connected between the Digital Power Supply Board and the mains transformer.

If you are feeling good about your connections install your AC plug into the back of the chassis and switch the unit ON (1 pressed flush to the chassis) – Note the LED's turn on.

Perform following VOLTAGE checks

Between A+ and AGND	+12v
Between D+ and DGND	+12v
Between A- and AGND	-12v

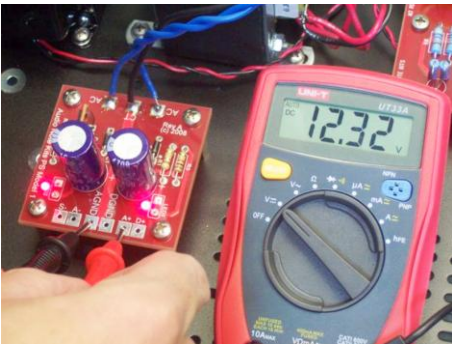

Between A+ and AGND

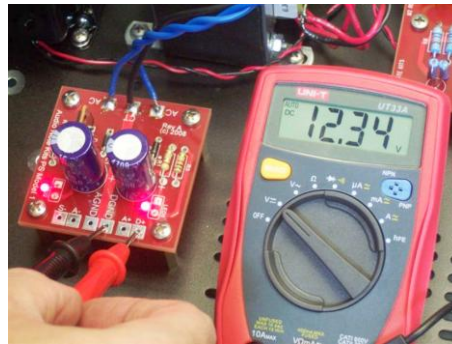

Between D+ and DGND

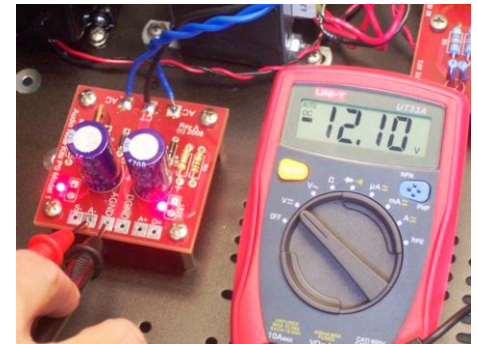

Between A- and AGND

This completes the Digital Power Supply PCB section – if you are having any problems with your voltage checks feel free to contact us for support.

## Section 6: Install the Screen

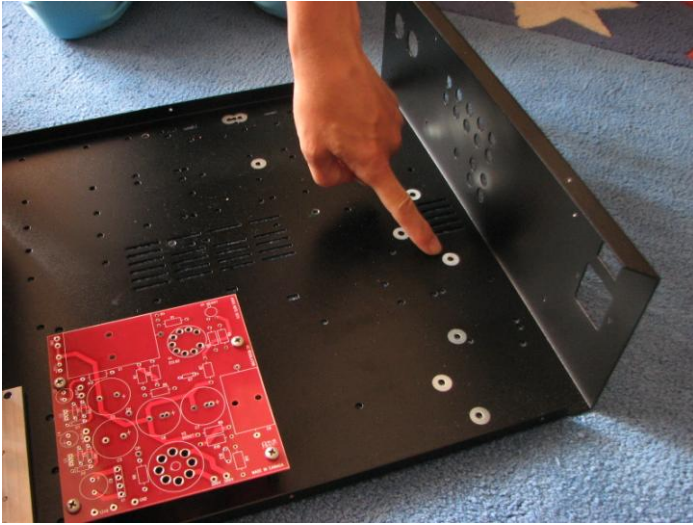

The next step is to install the metal screen.

It is important that a good electrical contact is maintained between the chassis and the screen itself.

This picture shows the hole that will make that contact from the chassis – note that the surrounding paint has been removed.

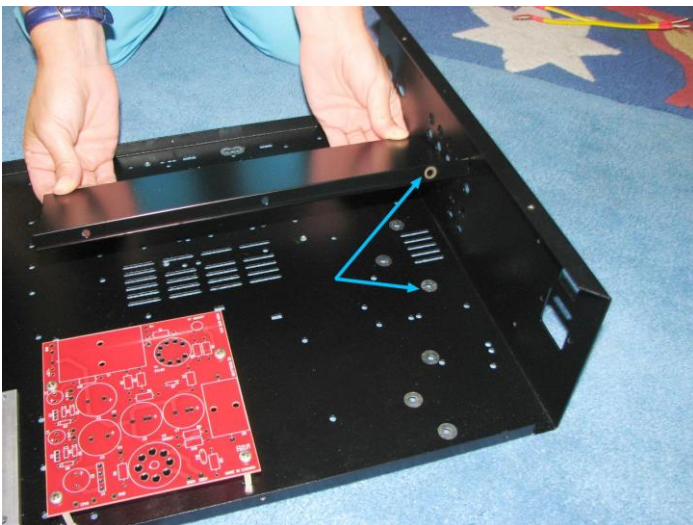

As you can see here, the screen has a corresponding hole where the paint has been removed.

These holes should mate and provide a good electrical contact.

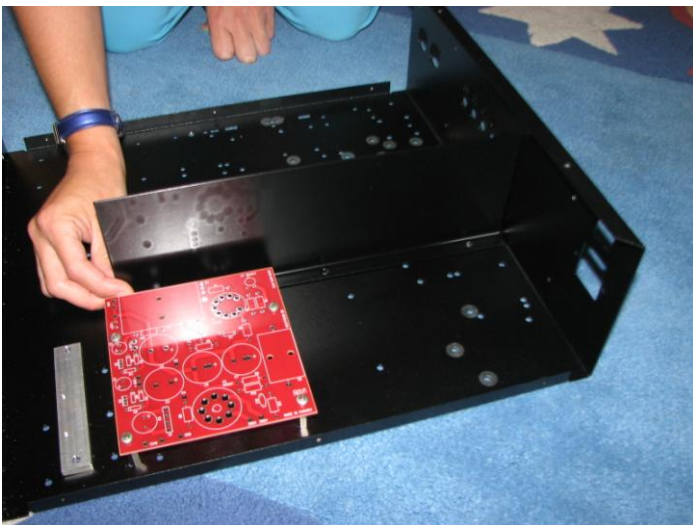

This picture shows the final position of the shield.

Use 3 M4 10mm screws and nuts to secure the screen in place - insert screws from underneath the chassis.

# Section 7: Installing the Digital PCB

## Digital Board Overview

The Digital Board is supplied with the kit built and tested. The board was originally designed for use in the DAC1.1 Kit, which had the analog filter and IV circuitry. This circuitry is removed now and you will notice tantalum resistors located in R34 and R35. These resistors are at the output of the DAC chip. In order to use the IV transformers we also need the 820pf capacitors in parallel with these resistors and you can see them installed in locations R44 & R43.

The Board was originally designed to support 75 ohm RCA input (CON1) and XLR 110 ohm (CON2). We are finding that now with the USB option there is a third choice. So what the board allows you to do is use any two of the three and you can switch between them. Most customers would either use RCA or XLR but not both so what we do then is use the USB on the other channel. The switch at S1 allows you to select which input. Currently this switch needs to be set on the board. The switch can also be hardwired in one way if you are always only going to be using just one input source.

On the Digital Signature Board we include the AN Toroidal input transformer and we custom install this on the channel that you require (RCA or XLR)

Typical scenarios today are people using RCA 75 ohm and also USB – So we are using the CON2 as the USB channel and you will notice that we have wired two of the three inputs together – the wired two are the GND for the SPDIF input (same as the RCA input signal and GND) - So you will want to connect the signal from the USB to the hole that is the large OVAL (not soldered) and the GND to either of the two remaining holes that are connected together

You will notice that when using the USB input on the “former” XLR input we have changed the value of R36 to 75 ohm – (it would be 110 ohm for XLR operation)  
If you ever want to change this back to XLR operation you can install the 110-ohm resistor back in this position.

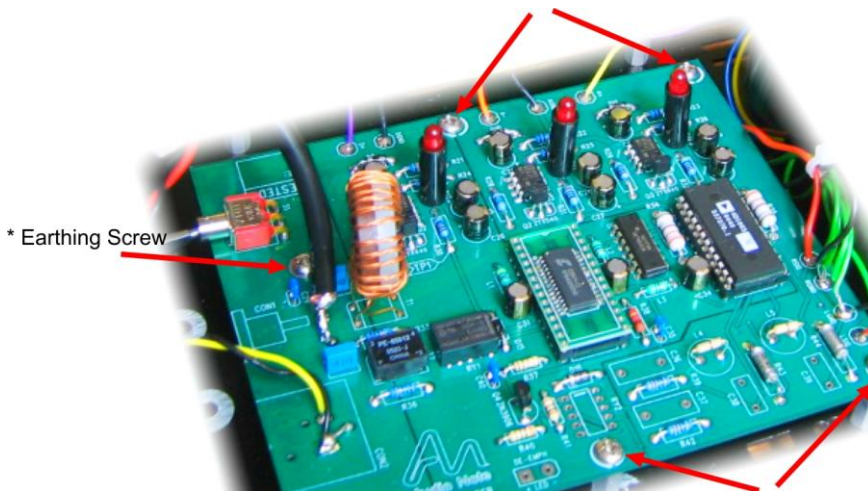

### IMPORTANT NOTE:

It is important that all five of the spacers and screws are used to secure the digital board in place.

One of these screws (see picture opposite) is used to earth the digital board directly to the chassis. If this 'connection' is not made securely, a great deal of hum and RF interference can result.

## Digital Board Installation

Install the 5 aluminum spacers on the board and position in the chassis.

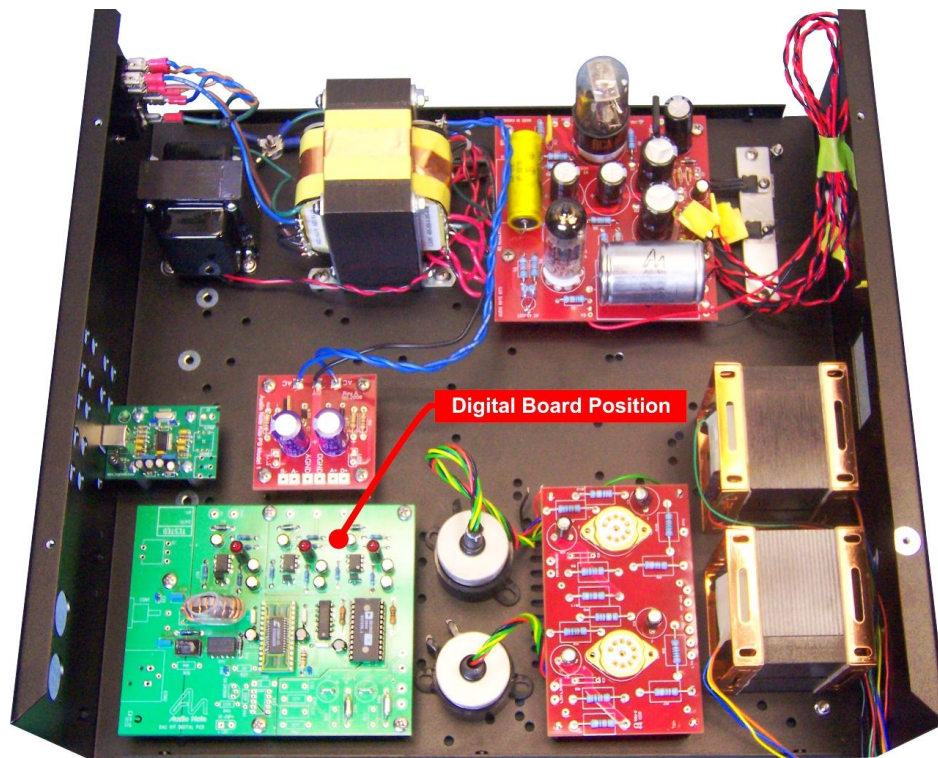

Once the board has been positioned in the chassis you will want to connect up the input RCA's.

You will need to install three RCA's – 2 are for the analog output and one is for the digital input.

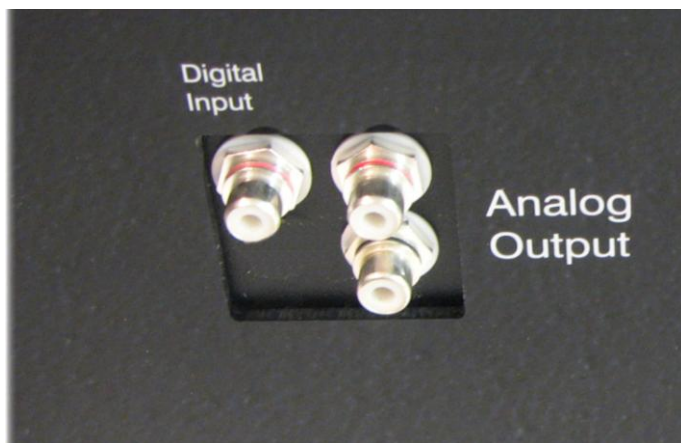

The RCA's on top of each other are the analog output RCA's, install these into position along with the single input RCA. You can use a red one on top and a black one below.

# Section 8: Digital Board Power Supply Connections

In this section we will make the connections between the digital Power supply (small red board) and the Digital DAC board (green board). This is quite straightforward and shouldn't present any problems.

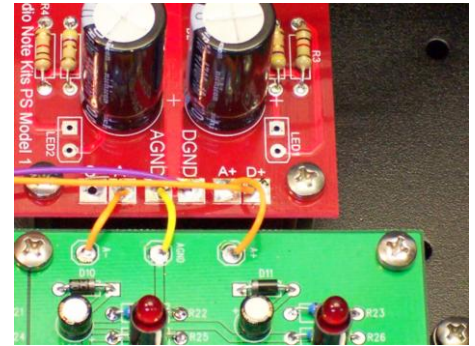
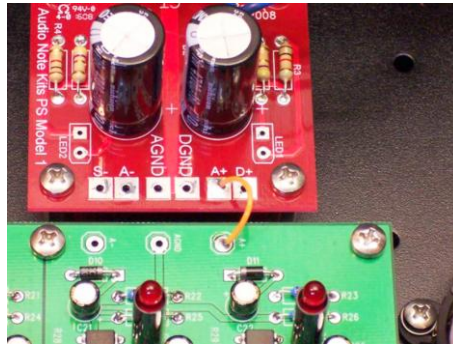
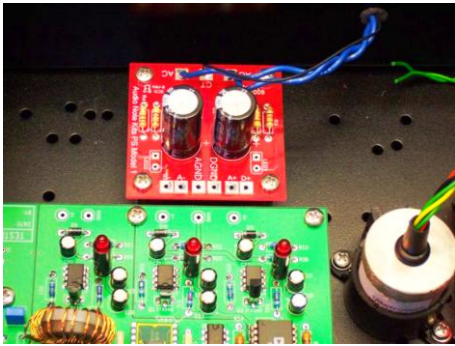

Please refer to the following wiring table:

Power Supply Pad	Digital Board Pad
AGND	AGND
A+	A+
A-	A-
DGND	DGND
D+	D+
S- (unused)	

Using the colored PTFE wire provided you can make connections between the named connections: A+, A-, AGND, D+, and DGND - the S- is not used (it is a spare output).

# Section 9: Line Board Construction

In this section we will be building the 5687 line board that is used to drive the output transformers in your DAC Kit 3.1. You can begin by securing the board spacers (shown in the first picture below).

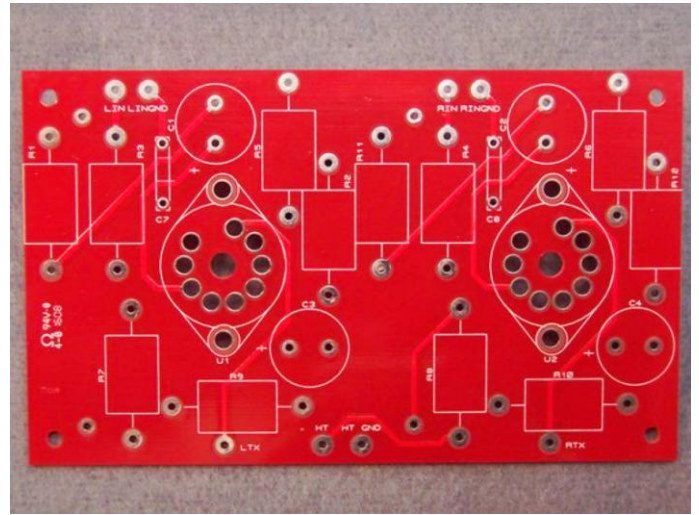
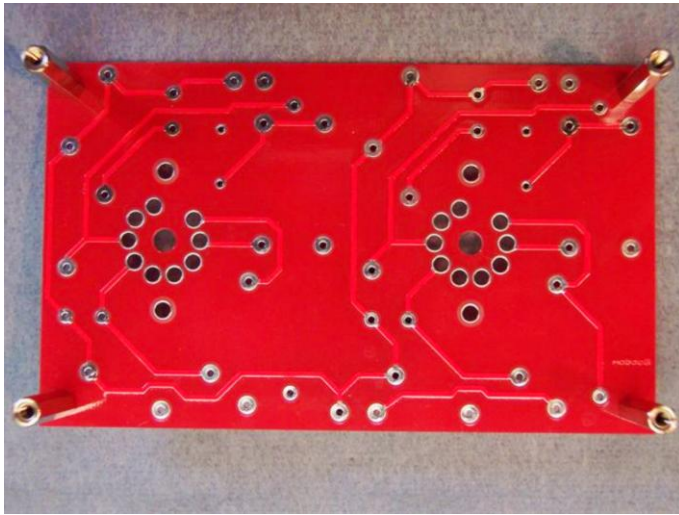

## Installing the Valve Bases

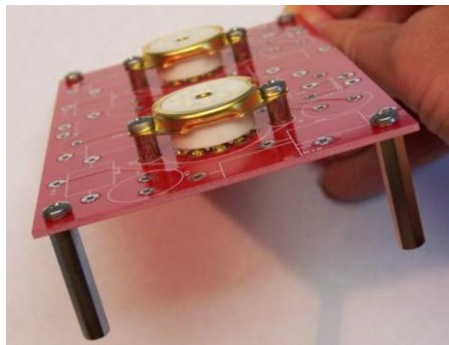
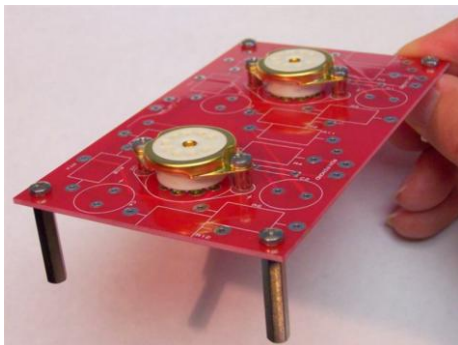





Install the 9-pin valve bases into position and secure each with the M3 16mm pan head screws, 6mm spacers and nuts on the underside of the board.

## Parts List

Category	Quantity	Part	Designator
Capacitors (Electrolytic)	4	470uf 16v	C1, C2, C3, C4
Capacitors (Non-polarized)	2	0.1uf 630v	C5, C6
Resistors	2	3K3	R1, R11
	4	1K0	R3, R4, R5, R6
	2	39K	R7, R8
	2	1K5	R9, R10
	1	1M	R2, R12

## Installing the Resistors

Resistors		2	3K3	R1, R11
		4	1K0	R3, R4, R5, R6
		2	39K	R7, R8
		2	1K5	R9, R10
		1	1M	R2, R12

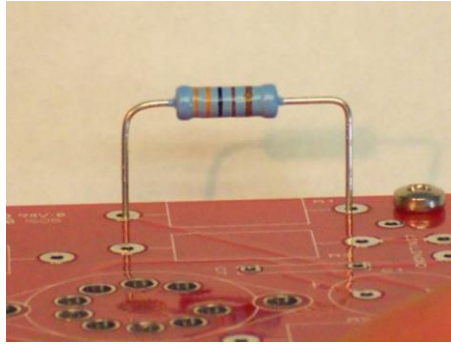
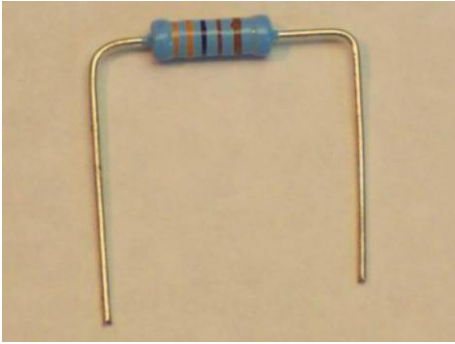

You will want to bend the resistors to the correct length for easy insertion into the board – I suggest that you place all the resistors into position and bend the legs gently on the under side of the board to make sure they stay in one place – also line them up so that all the color codes are readable in the same direction.

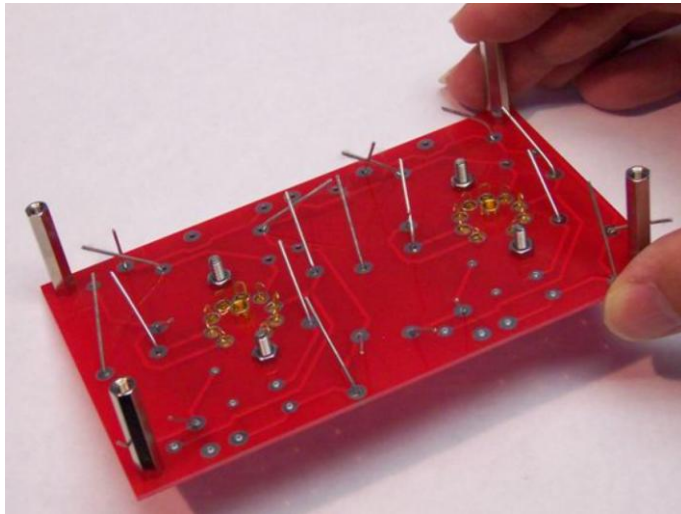

Once the resistors are placed, check them with picture on the next page and the parts list for correct values before soldering.

Solder all the resistors AND the VALVE BASES into position. Once soldered, clip off all the component legs from the underside of the board.

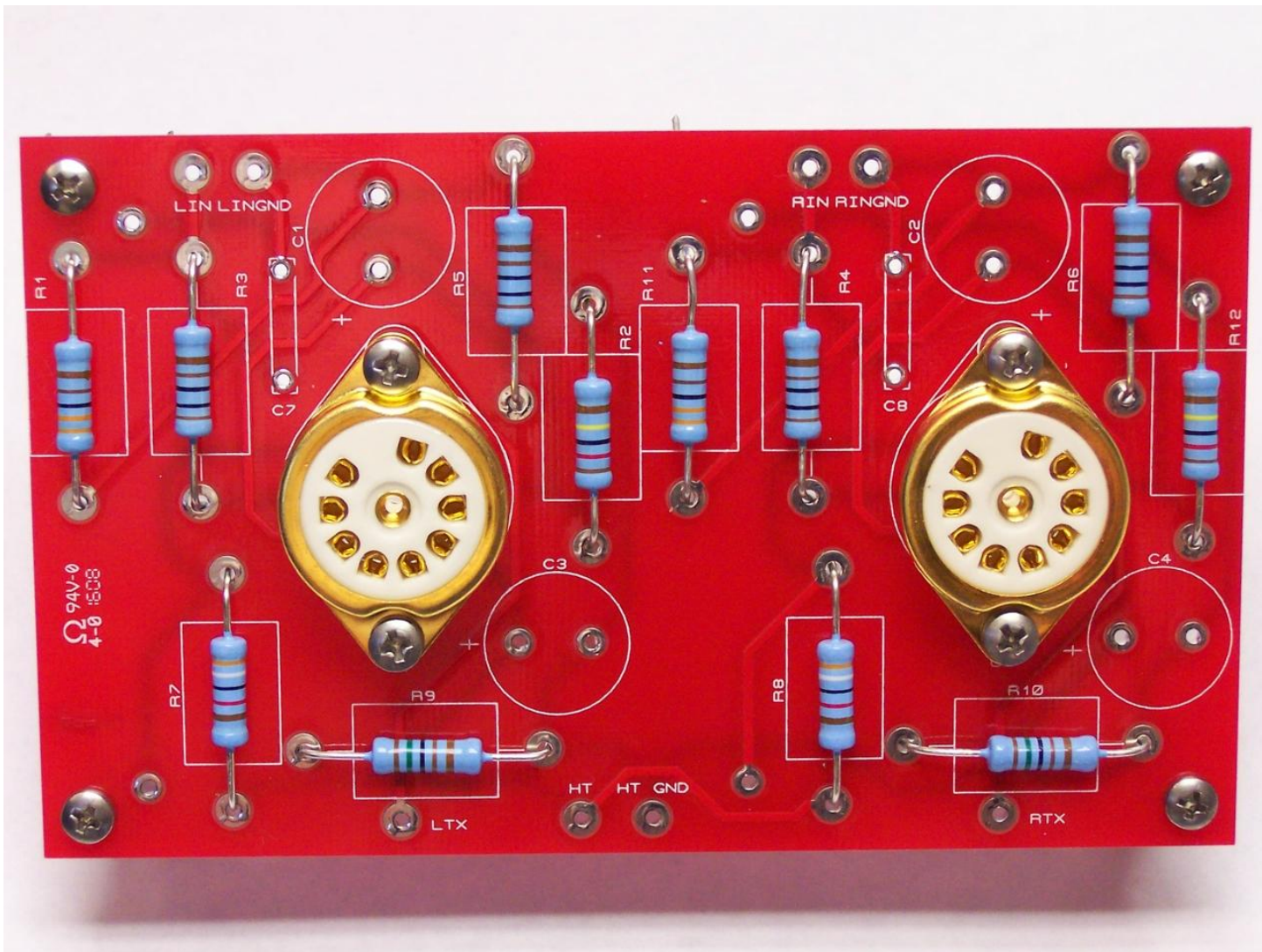

Above you can see the resistor installation / valve bases completed

## Installing the Electrolytic Capacitors

Capacitors (Electrolytic)	4	470uf 16v	C1, C2, C3, C4
---------------------------	---	-----------	----------------

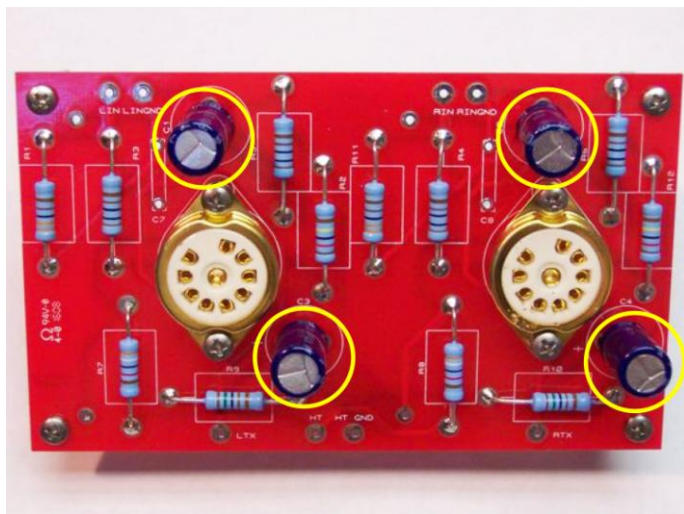

The next step is to solder in the 4x 470uf 16v capacitors.

These capacitors are electrolytic and **they are polarized which means they have to go in a certain way** - the capacitor has a long leg and a short leg - the short leg is the negative side and the long leg is the positive side.

You will see a + marking on the board, align the long leg on the side closest to the + marking on the PCB.

## Installing the Film (non-polarized) Capacitors

Capacitors (Non-polarized)	2	0.1uf 630v	C5, C6
----------------------------	---	------------	--------

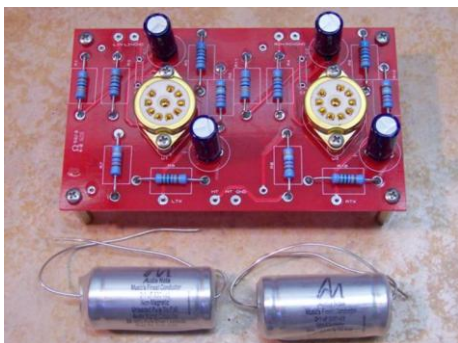

The final step is to install the 2 x 0.1uf 630v film capacitors. These can go in either way but it is recommended that the strip is on the side with the analog signal entering. These capacitors will be installed on the underside of the board as shown opposite - the reason for the heat shrink is because the casing on the caps is conductive and could short any circuitry touching the case.

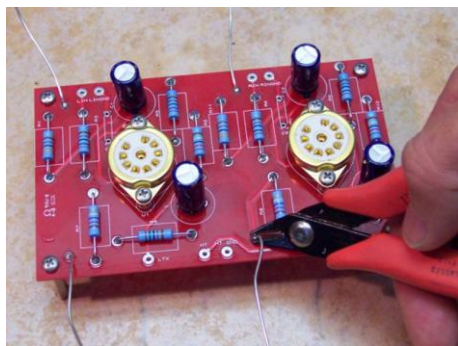

You can then proceed to cut the extra leads. Note that these are made from silver wire so may be very useful to keep around for future projects!

## Board Orientation

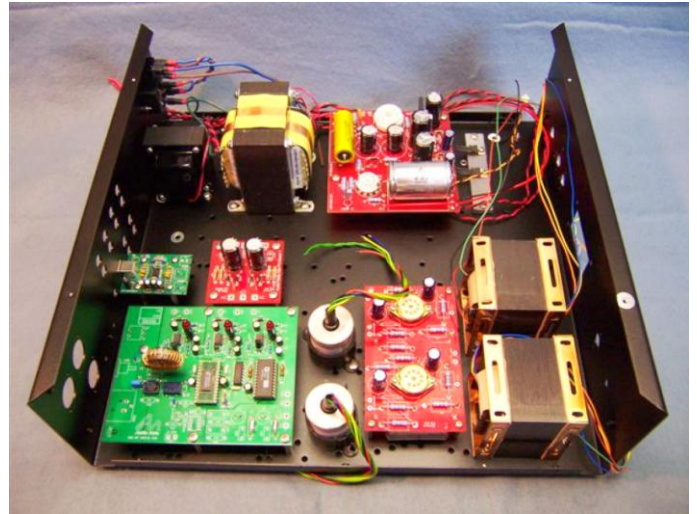
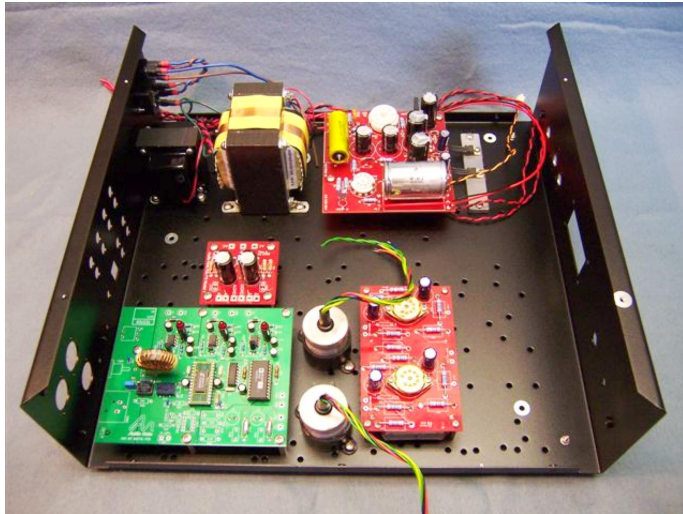

The above pictures show the correct installation of the new 5687 line board into the chassis.

## 5687 Filament Wiring

There are two pairs of filament wires coming from the M2 power supply boards. Each pair connects to one of the 5687 valve bases. One wire from each pair will connect to **pin 4** and the other to **pin 5**. It does not matter which color from each pair connects to which pin but it is a good idea to be consistent between the valve bases as to which is used.

## Section 10: Installing I/V transformers

In this section we will install the I/V transformers into the DAC.

Secure the I/V transformers in their clamps with their leads facing upward and so they are flush with the bottom of the clamp where the fixing holes are situated. Then fix the clamps into position in the chassis as shown in the following picture.

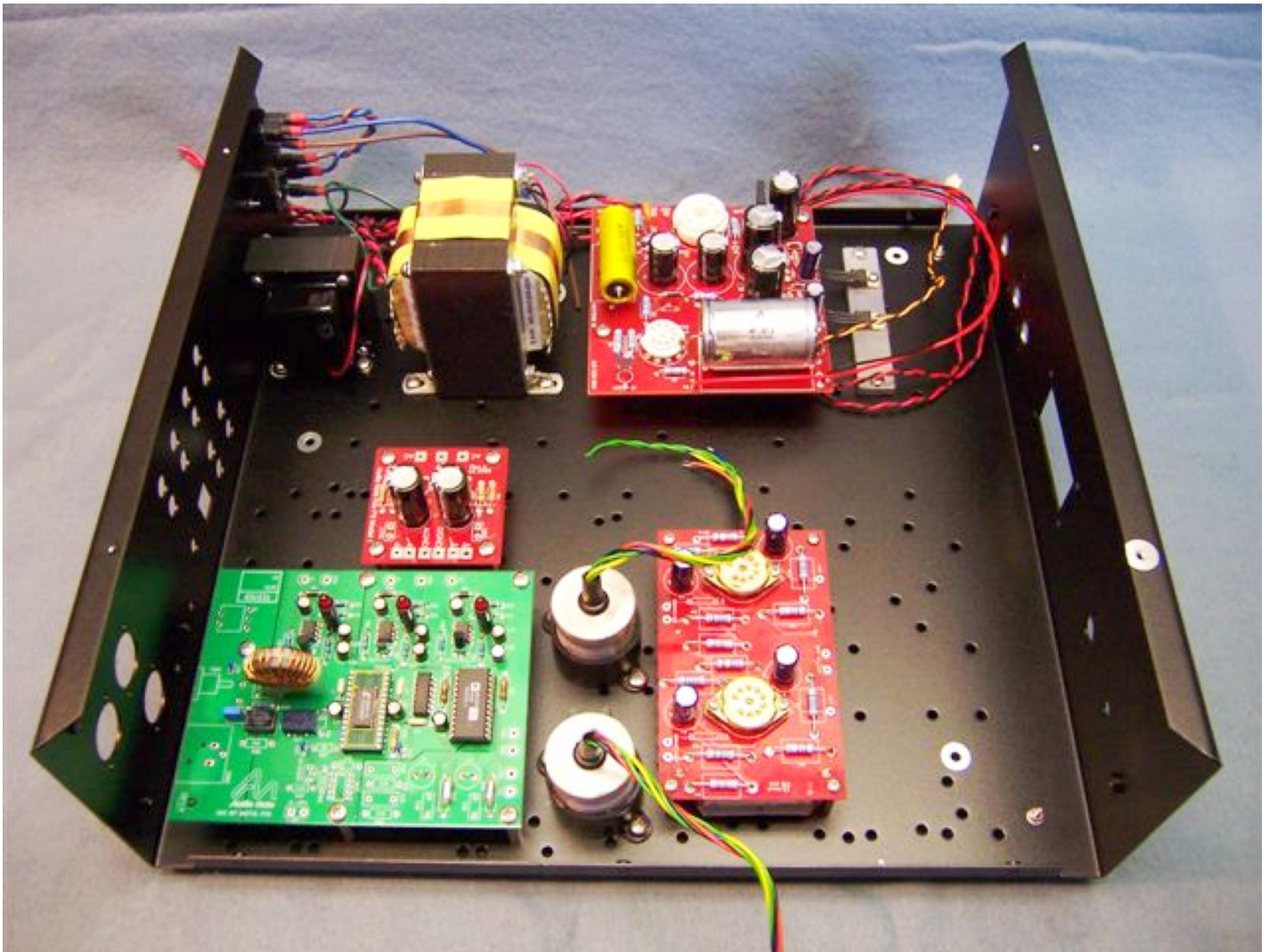

Above, you can see the I/V transformers installed in the chassis in between the analog output board and the digital board.

## Wiring the I/V Transformers

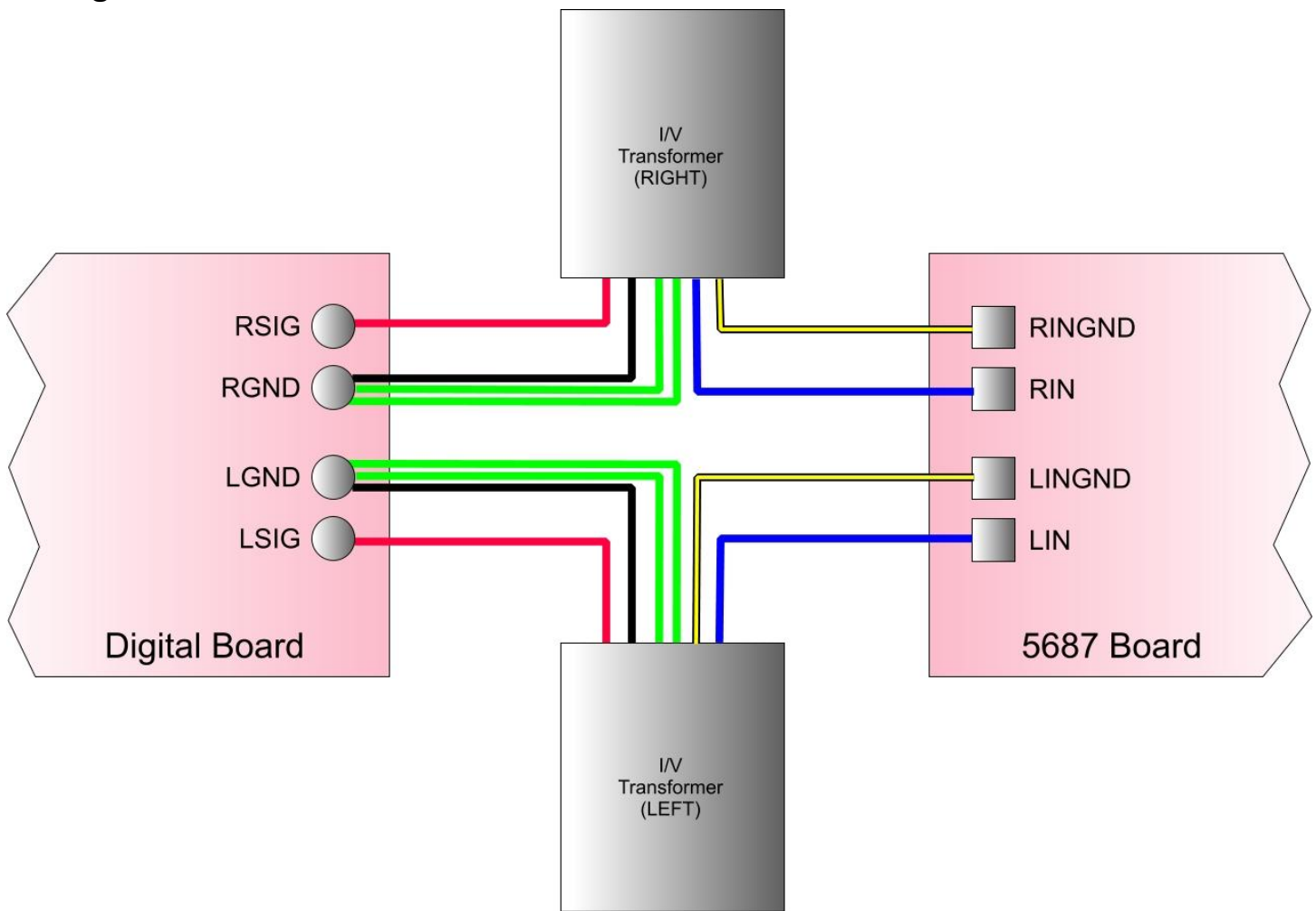

All you need now to do is connect the Red lead from the Left I/V transformer to the LSIG and the Black lead from the left I/V transformer to the LGND on the Digital Board.

Repeat for the Right I/V transformer.

- RSIG RED (right I/V)
- RGND BLK (right I/V)
- LSIG RED (left IV)
- LGND BLK (left IV)

You will also want to connect two green wires from each I/V transformer to the Digital Ground for each channel.

Now that we have installed correctly the interface between the IV's and the digital Board side we now need to do a similar thing on the 5687 analog board.

Solder the Blue wires to left and right channel inputs (LIN / RIN). Then solder the corresponding Yellow wires to the input Ground LINGND (Left Input Ground), RINGND (Right Input Ground).

# Section 11: Connecting the 5687 Output

## Connecting the 5687 HT to the power supply

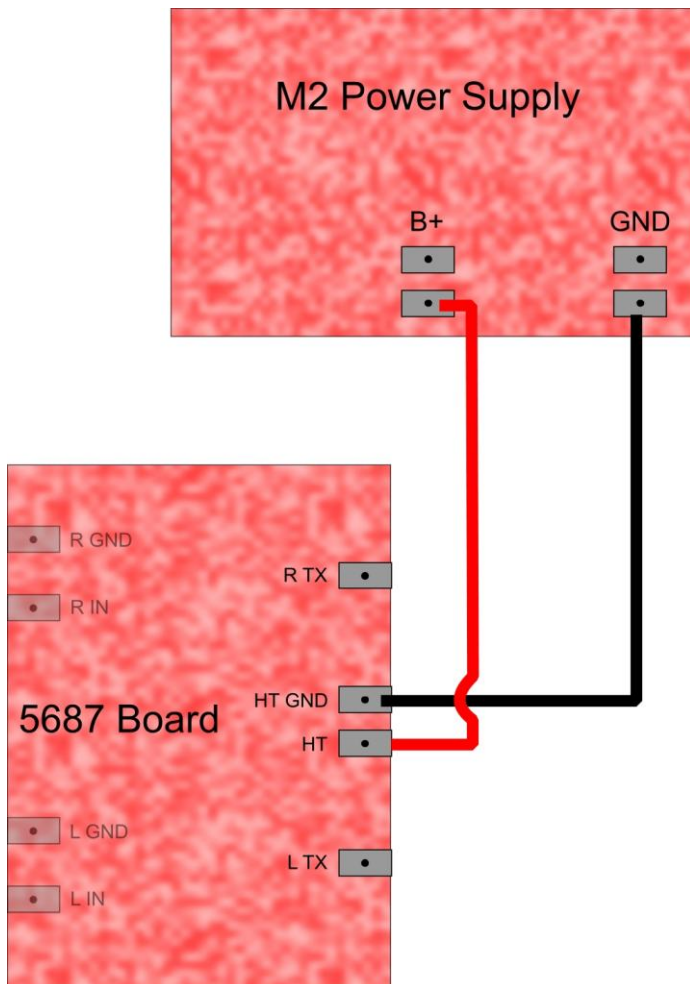

First, we need to connect the 5687 board to the M2 Power Supply board. The connections for this can be seen in the diagram shown opposite.

Take a red wire and connect between the HT pad on the 5687 board and one of the B+ pads on the M2 Power Supply board.

Take a black wire and connect between the HT GND pad on the 5687 board and the GND pad on the M2 Power Supply board.

It is a good idea to connect to one board and twist the wires together - making a twisted pair, before connecting to the other board.

## Connecting the Output Transformers

We essentially have two different types of output transformer when it comes to connecting up. The first (Type 1) can only be connected in single-ended mode. The second (Type 2 - which includes Double C-Core types) can be connected in either single-ended or balanced configuration. Please ensure that you are using the connection information that is relevant to the transformers that you have purchased with the kit.

## Output Transformer Type 1 (Single-ended Only)

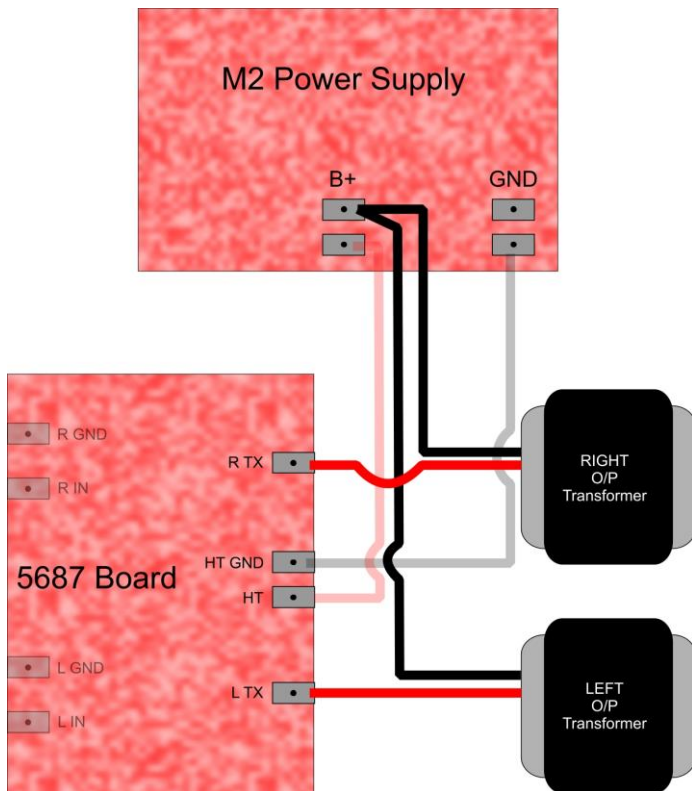

As you can see from the diagram, the Black leads from each of the transformers connect to a B+ pad on the M2 Power Supply board.

The Red lead from the **Right** output transformer connects to the **R TX** pad on the 5687 board.

The Red lead from the **Left** output transformer connects to the **L TX** pad on the 5687 board.

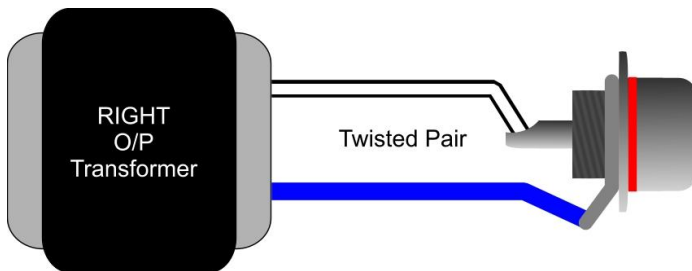

This type of output transformer has a Blue and a White lead at its output.

The Blue and White leads from each transformer should be twisted together and the twisted pair connected to its relative RCA output connector.

Connect the Blue lead to the RCA's earth tag.

Connect the White lead to the RCA's signal tag.

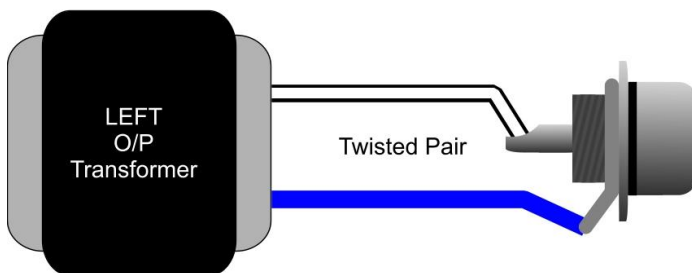

Note that the diagram only shows a 'shortened' version of the connections for clarity. In reality, you will be taking these leads from the front of the chassis, all the way to the back of the chassis.

## Output Transformer Type 2 (Single-ended or Balanced)

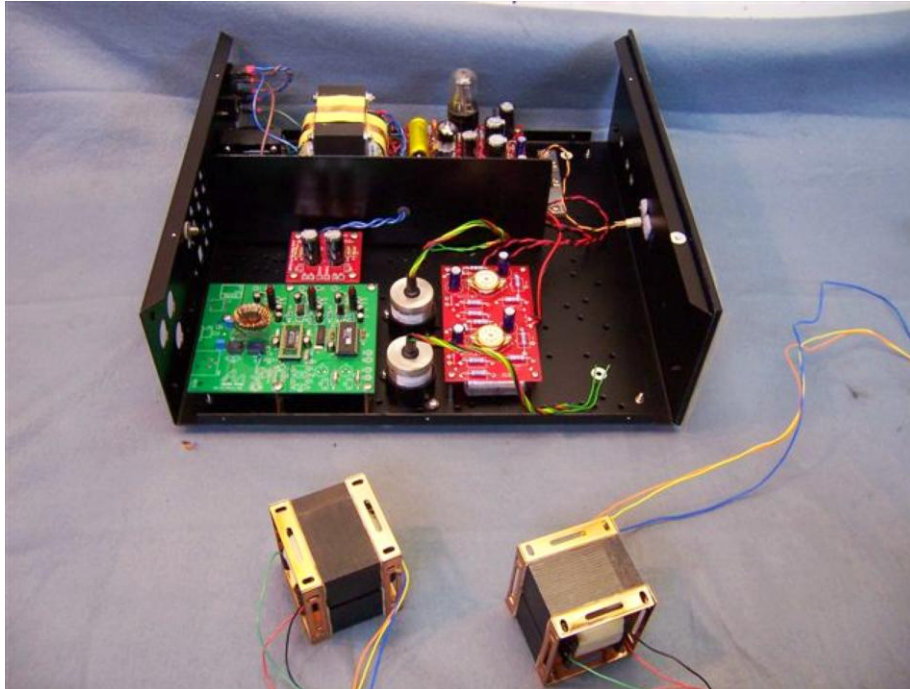

Above we can see the pair of output transformers used in the DAC output stage

We are now ready to connect the output transformers to both the output of the 5687 analog board and to the RCA (single-ended) or XLR (balanced) outputs.

### Connecting the Primary Windings

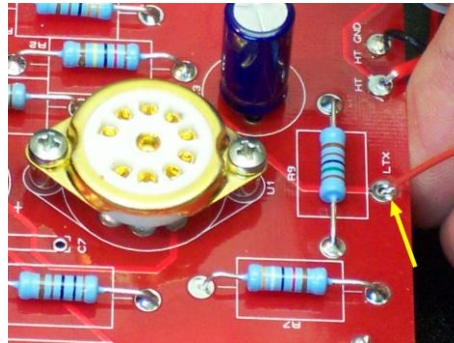
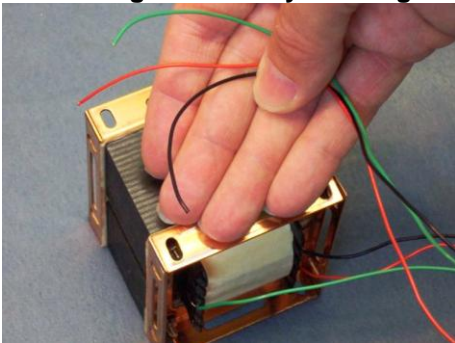

The picture on the far left shows the Primaries (or input) of the transformer.

GREEN Wire – connects to GROUND on the 5687 Board.

BLACK WIRE – connects to HT on the 5687 board.

RED Wire – connects to RTX for right channel, LTX for Left Channel.

### Connecting the Secondary Windings

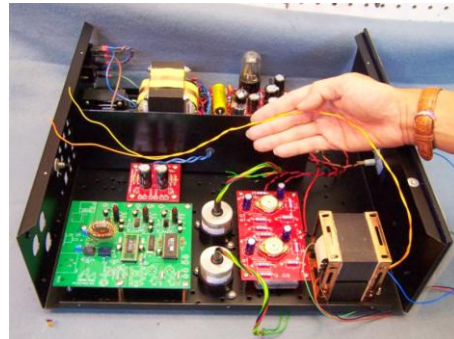
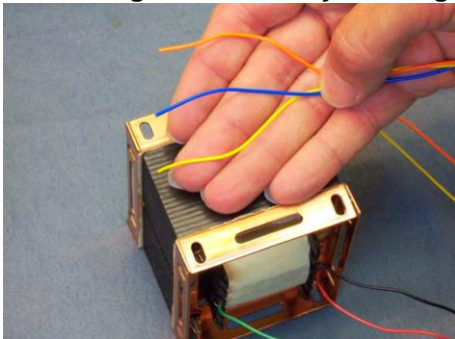

The picture on the far left shows the secondaries (or output) leads of the transformer.

These leads will connect to the XLR and RCA outputs.

For RCA operation each transformer will connect to the output RCA via the yellow (GND) and orange (signal).

## Section 12: Source Selection and Switching

The DAC3.1 Digital Board has two inputs on it – CON1 and CON2. A selector switch is used to select which input source will be used. This allows switching between two different digital input type sources. You may choose between any two of the following input types:

- RCA.
- XLR.
- USB (requires additional USB board).

### *Installing the Input Selector Switch*

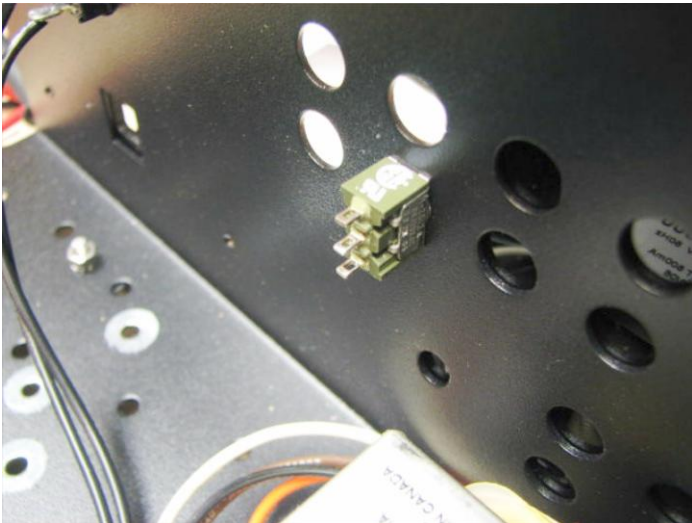

Install the toggle switch provided at the back of the chassis in the bottom left corner position that is available after the rear faceplate has been installed.

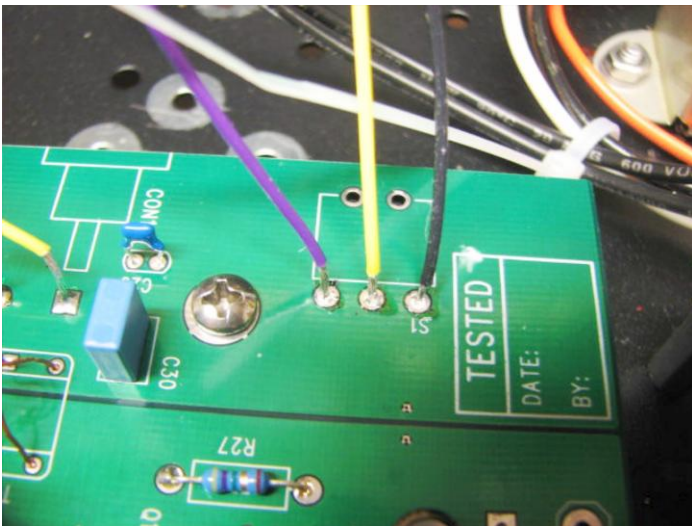

We are going to hook up 3 wires to the 3 positions on the Digital board as shown here.

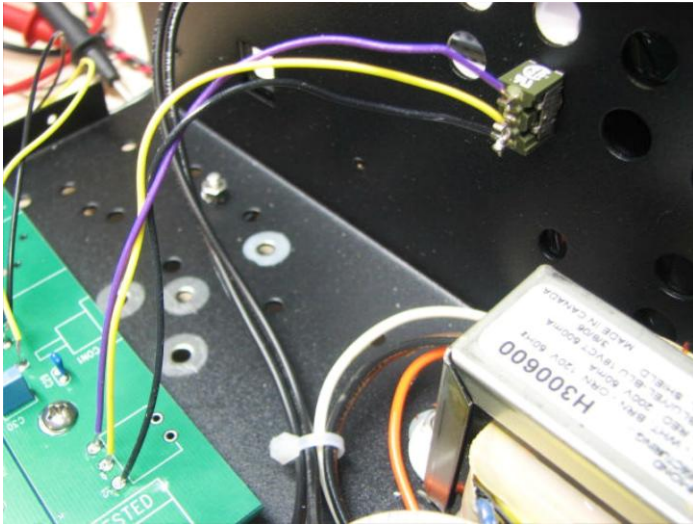

This picture shows how the pins on the back of the switch are connected to their relevant position on the digital board.



Here you can see the wiring between the switch and the Digital Board.

This will now allow us to toggle between the CON1 input and the CON2 input.

## ***Input Connections***

Typically you will wire the RCA input into CON1. Then either use the XLR input or the USB input for CON2.

If you are using a USB input then you will install the 75-ohm resistor in R36 on the digital board.

If you are using the XLR input then you will install 110-ohm resistor into R36 on the digital board - this may have been installed at the factory based on your configuration (USB XLR for example – but can always be changed later).

The bottom line is that you can configure your DAC to support any two of the three source inputs (USB, RCA XLR) and can be switched over at a later time to accommodate a different two.

## Connecting the RCA Input



To connect the RCA input you will want to use the Coaxial cable length supplied.

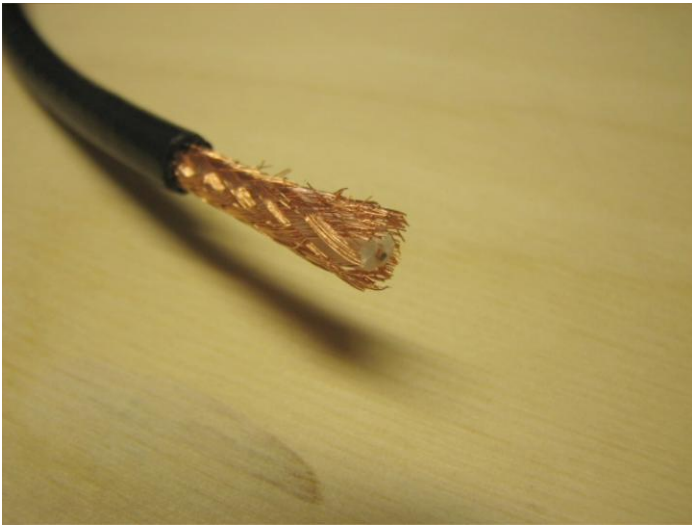

Strip the outer casing to expose the grounding shield as shown opposite.



Separate the ground shield and twist together.

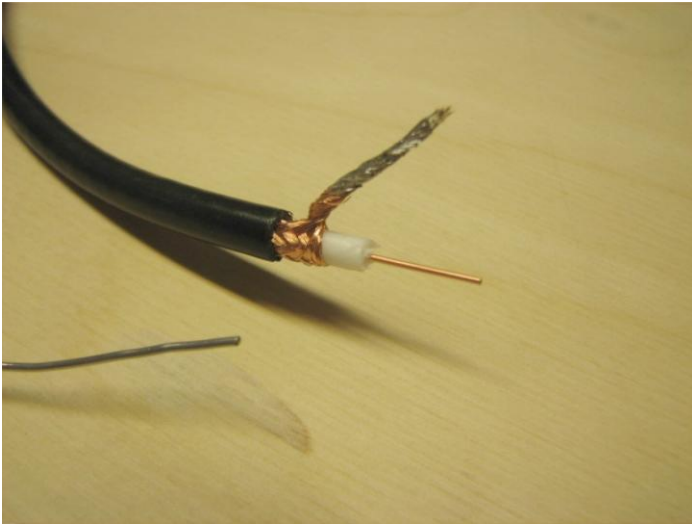

Now TIN the shield by adding solder to it.

Now repeat this process at the other end of the cable.

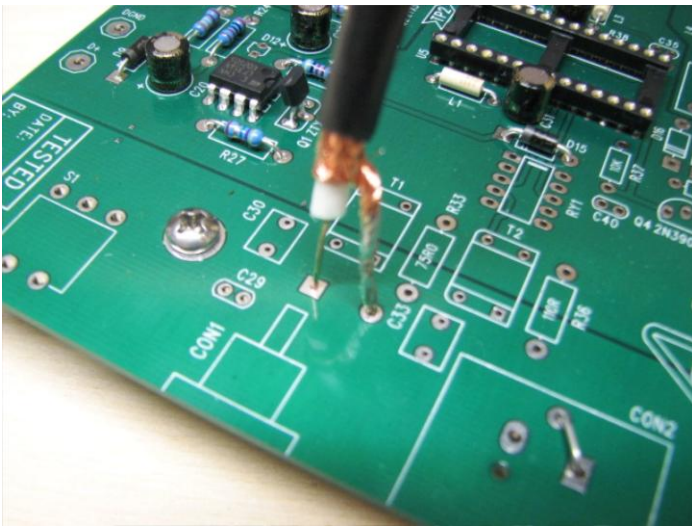

This picture shows how the solid core will fit into CON1 and the shield will be soldered to the pad beside it.



This picture shows how the other end of the cable will connect to the RCA connector. The RCA connector must first be attached to the rear panel as follows:

Install the single RCA into the back panel in the top left corner of the 4 positions available and then solder the Co axial cable to the RCA.

## Connecting the USB Input

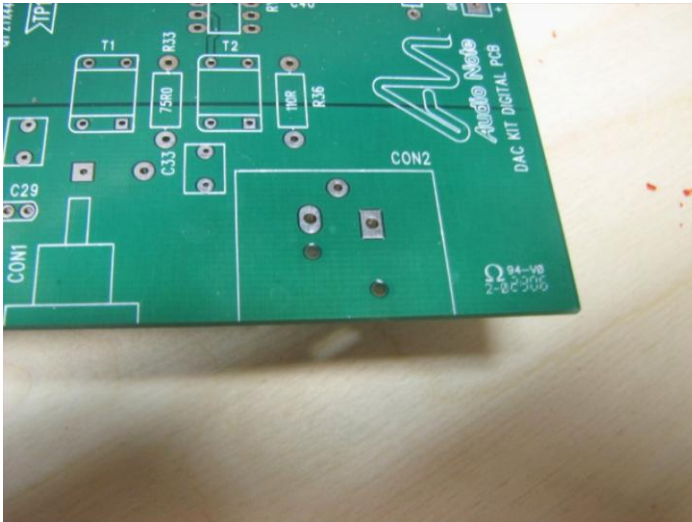

If using the USB input then you will want to examine the three holes in the “XLR” footprint on the Digital Board.

You will notice that there are three holes that the XLR would normally fit into – this is where we are going to hook up the USB inputs.

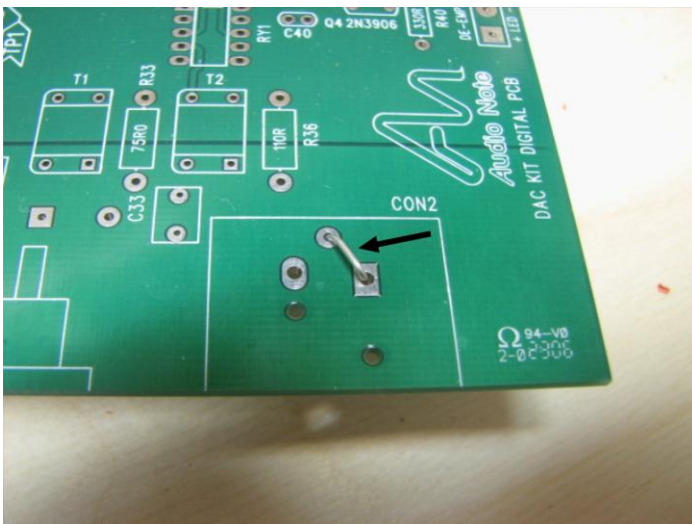

To prepare for USB connection you will need to put a jumper from the circular pad in the center to the rectangular pad on the right.

This is the GROUND connection and the signal from the USB goes to the loan OVAL pad.

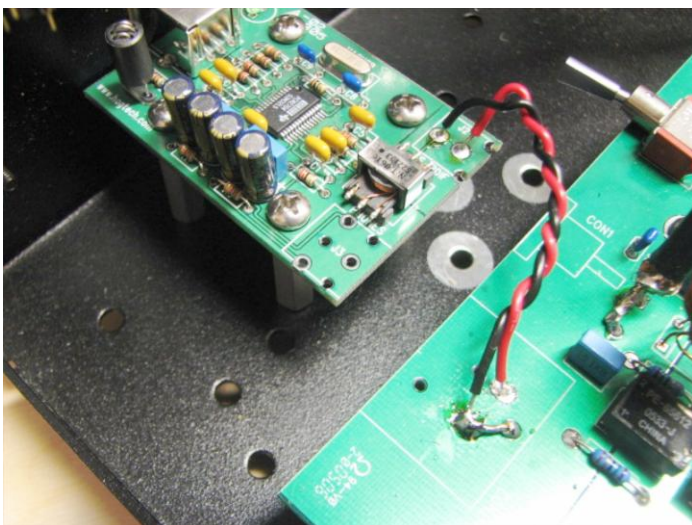

This picture shows the connection of the USB (signal – red) to the Digital Board input.

## Connecting the XLR Input

For **XLR Operation** you will mount the XLR connector in the back rear position and then connect the wires from the XLR to the digital board – just the same way that you connected the switch.

# Section 13: Turn-on Procedure

At this point we should be finished – we have two working power supplies – Perform the following checks:

Make sure that the Digital Power Supply is connected correctly to the Digital Board.

At this point we can try the turn on – we should see the 3 LED's on the Digital Board Light up – If they do not then I would suggest rechecking the inter-wiring to the digital board and the power supply and or measuring the voltages again.

A-	-13V
A+	+13V
D+	13V

If all of the LED's are on, we should try putting a digital source into the DAC.

We have provided you with an audio test CD with one track on it generating a 1Khz sin wave that should allow you to get a solid AC voltage measurement at the output of the DAC – 1V RMS (AC measurement!).

Plug in the digital source using a 75-ohm RCA cable (or any spare RCA cable for now) into the DAC. You will probably hear the relay chatter when you first connect or the digital board receives a digital signal. If the chattering continues then power down the DAC and power on again in a few seconds – all should be well.

Connect the analog outputs to a line level pre-amplifier or an integrated amplifier and check to hear the sound!

The M2 Power supply can take up to 45 seconds to turn on so be patient when you are waiting for the music to play.

Congratulations if you have a working DAC3.1 Kit. Feel free to contact us to share your excitement or if you are having any problems on the debugging front!

# Final Thoughts

The kit is fairly complex and we would welcome any feedback on the manual/ instructions, parts list, build instructions – Any omissions etc...

If you feel that you can take some really good pictures of your build process or even final build we would like to see your work. If you have any suggestions that you feel would help other kit builders then send it over in e-mail and I will collect and we will put a DAC3.1 support page for other users.

# Appendix

The appendix contains auxiliary information. That is information that is either common to most project manuals or any last minute pieces of information that did not make it into the manual in time. It may also contain pull-out circuit diagrams that may be handy to have outside the manual etc.

# Resistor Color Codes (5 band)

	Black	- 0
	Brown	- 1
	Red	- 2
	Orange	- 3
	Yellow	- 4
	Green	- 5
	Blue	- 6
	Violet	- 7
	Grey	- 8
	White	- 9





























Resistor color codes are read from the color that is nearest the edge of the resistor - that is treated as the first column.





























The first column of a 5-band resistor is the 100's column, followed by a 10's column, followed by a units column.

The fourth band is a multiplier (or decimal point shifter). The multiplier can use the additional colors silver and gold. These are used for very small values and turn the multiplier into 0.01(silver) and 0.1 (gold). For the standard colors, it determines how many times the column value is shifted to the left (i.e. multiplied by 10)

The fifth column is a tolerance value. These can be quite complex but we will not concern ourselves with these.

## Examples

100R				
	1	0	0	x 1
680R				
	6	8	0	x 1
820R				
	8	2	0	x 1
1K				
	1	0	0	x 10
2K2				
	2	2	0	x 10
2K7				
	2	7	0	x 10
3K3				
	3	3	0	x 10

10K				
	1	0	0	x 100
68K				
	6	8	0	x 100
82K				
	8	2	0	x 100
330K				
	3	3	0	x 1,000
220K				
	2	2	0	x 1,000
470K				
	4	7	0	x 1,000
1M				
	1	0	0	x 10,000

You can also find an 'Interactive Resistor Color Code Calculator' on our website (available from the Links page).

# Analog Board Schematic

AudioNote Kits - DAC Kit 2.1	
Level C 5687 Output	Rev. 1.3 - 18th July 2008

## LEFT Channel

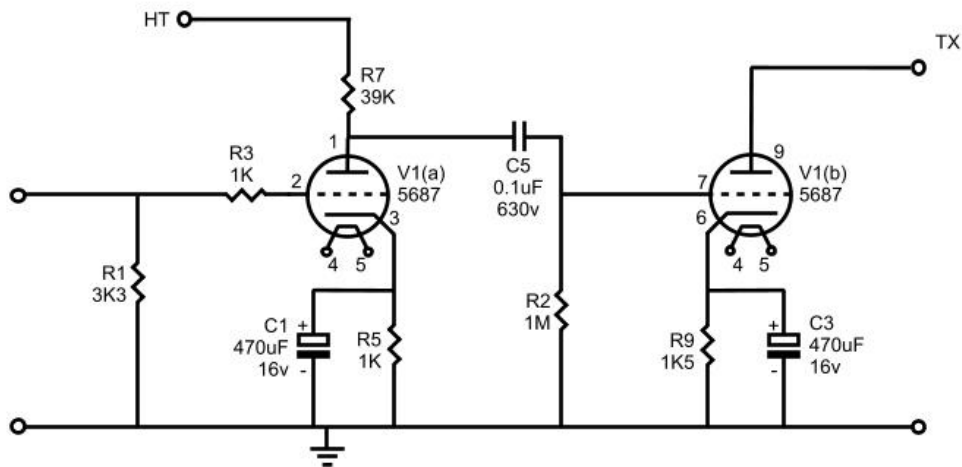

## RIGHT Channel

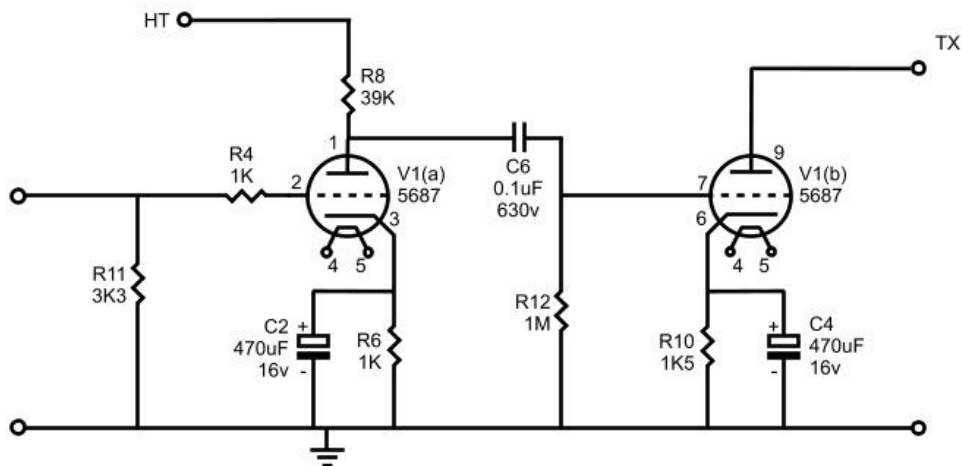

# M2 Power Supply Board Schematic

**AudioNote Kits - M2 Power Supply**  
**250-300v 12v FIL**      **Rev. 1.0 - 12th May 2006**

